



F:

Ouvrez toutes les boîtes et assurez-vous que le contenu est correct.

Triez toutes les parties conformément à l'utilisation indiquée sur le contenu des boîtes.

Les 7 types d'utilisation sont :

- Façade
- Parois
- Toit
- Porte
- Lucarne
- Vitrage
- Finition

E:

Open all the boxes and make sure the contents is correct.

Sort all parts according to the usage which is mentioned on the contents of the boxes.

The 7 types of usage are :

- Facade
- side panel
- Roof
- Door
- Skylight
- Glazing
- Finishing

NL:

Open alle dozen en controleer of de inhoud klopt.

Sorteer dan alle onderdelen volgens gebruik, die vermeld staat op de inhoud in de dozen.

De 7 soorten van gebruik zijn :

- Gevel
- Zijwand
- Dak
- Deur
- Dakraam
- Beglazing
- Afwerking

D:

Öffnen Sie alle Boxen und kontrollieren Sie dass der Inhalt richtig ist.

Sortieren Sie alle Teile nach der Anwendung, die auf dem Inhalt der Boxen angegeben wird.

Die 7 Arten der Anwendung sind :

- Fassade
- Seitenwand
- Dach
- Tür
- Dachfenster
- Verglasung
- Finishing

Beste klant,

Proficiat met de aankoop van uw serre.

Door deze handleiding is geen technische voorkennis vereist.

Doorneem alles stap per stap, zodat noodzakelijke onderdelen en handelingen voorbereid zijn.

Veiligheid en efficiëntie

Glas is zwaar, scherp en breekbaar.

Een ladder is hoog en wankel.

Aluminiumprofielen zijn soms lang en scherp.

Wees voorzichtig als u niet dagelijks met deze grondstoffen werkt.

Kinderen blijven beter uit de buurt!

Veiligheidsschoenen, een veiligheidsbril en handschoenen kunnen hierbij helpen, bij de montage van glas zijn deze een must.

Gereedschappen:

- 2 sleutels met sleutelwijdte 10mm
- mes of een stevige schaar
- sterschroevendraaier (groot type)
- platte schroevendraaier (groot)
- waterpas
- spade
- touw of een meter van min. 5 meter
- ladder (die op zichzelf kan blijven staan)

Toebehoren verkrijgbaar in elke doe-het-zelf winkel:

- neutrale silicone
- sneldrogende beton, om uw serre vast te ankeren

Weetjes

- Boutgleuven zijn gleuven waar de kop van een bout in past.

Bijna elk profiel in deze serre bezit 1 of meerdere boutgleuven.

- Bij verbindingen met boutgleuven, steeds de profielen goed tegen elkaar drukken.

- Wachtbouten zijn bouten die we in een gleuf schuiven als voorbereiding voor een latere montage,

op een tiental centimeter van het profieleinde houden moeren ze voorlopig vast.

- Een serre bestaat uit 2 gevels, 2 zijwanden en 1 dak.

- Indien niet specifiek vermeld, worden steeds korte bouten (M6x10) gebruikt.

Advies

Gebruik steeds alle detailzichten als hulpmiddel voor het uitlijnen, uitrichten en positioneren van uw profiel.

Let op doorsnede en gaten.

De moeren enkel 2 toertjes op de bouten draaien, pas na het doorlopen van de volledige pagina de bouten en moeren definitief aanspannen.

Bij het gebruik van silicone raden wij aan 'silirub PC' te gebruiken. De aangebrachte silicone heeft een levensduur van 1 jaar en wordt best regelmatig vervangen (hiervoor kunt u 'sealant remover' gebruiken). Het is heel belangrijk dat de silicone in de juiste omstandigheden wordt aangebracht:

- Bij droog weer
- In normale temperaturen (geen extreme koude of warmte)
- Op ontvette ondergrond (eventueel 'cleaner & degreaser' gebruiken)
- 1 dag laten uitdrogen

Cher client

Félicitations avec l'achat de votre serre. Cette notice de montage vous aidera à installer cette serre sans aucune connaissance technique préalable. Parcourez d'abord chaque étape cette notice, pour préparer tous les éléments et les opérations avant d'entamer le montage proprement dit.

Sécurité et efficacité

Le verre est un matériau lourd, coupant et fragile. Une échelle est haute et n'est pas stable. Les profils en aluminium sont souvent longs et tranchants. Prenez donc les précautions nécessaires, surtout si vous n'êtes pas habitué à ce genre de travail. Gardez les enfants à distance. Des chaussures, des lunettes et des gants de sécurité sont utiles et, pendant le montage du vitrage, indispensables.

Outils:

- 2 clés avec écartement de 10mm
- un couteau ou des ciseaux solides
- un tournevis Philips (grand)
- un tournevis pour vis à fente (grand)
- un niveau à bulle
- une bêche
- une corde ou un mètre d'au moins 5 m
- une échelle (double)

Accessoires en vente dans tout magasin de bricolage:

- silicones neutres
- béton à prise rapide, pour l'ancrage de votre serre

Bon à savoir

- Les encoches pour boulons sont des encoches ajustées aux têtes des boulons qui y seront fixés. Pratiquement tous les profils de cette serre sont pourvus d'une ou plusieurs encoches pour boulons.
- Pour les raccordements avec encoches pour boulons, veuillez toujours à bien presser les profils les uns contre les autres.
- Les boulons d'attente sont les boulons à introduire dans l'encoche pour préparer le montage ultérieur; ils sont provisoirement tenus en place par des écrous, à une dizaine de centimètres du bout des profils.
- La serre est composée de 2 façades, de 2 parois latérales et de 1 toit.
- Sauf indiqué autrement, on utilise des boulons courts (M6x10).

Conseil

Servez-vous toujours de tous les détails agrandis pour aligner, centrer et positionner les profils. Faites attention à la section et aux trous. Vissez les écrous à 2 tours seulement sur les boulons, et attendez d'avoir parcouru la page jusqu'au bout avant de serrer les boulons et les écrous définitivement. Nous vous recommandons d'utiliser silicone "silirub PC". Le silicone appliqué sur les parties a une durée de vie de 1 an et il est préférable de le remplacer régulièrement (vous pouvez utiliser un "dissolvant de mastic" pour cela). Il est très important que le silicone soit appliqué dans les bonnes conditions:

- par temps sec
- à des températures normales (pas de froid extrême ni de chaleur)
- Sur des surfaces dégraissées (éventuellement utiliser "nettoyant & dégraissant")
- Laisser sécher pendant 1 jour

Dear Customer

Congratulations on the purchase of your greenhouse. Thanks to this manual, no technical foreknowledge is required for assembling the greenhouse. Reading through the manual step by step will allow you to prepare all necessary parts and acts for the assembly of your greenhouse.

Safety and Efficiency

Glass is heavy, sharp-edged and fragile. A ladder is high and unstable. Aluminium profiles are sometimes long and sharp-edged. So, be careful when you are not familiar with handling these materials. Therefore, it is better to keep children away during the assembly. Safety shoes, safety glasses and safety gloves may therefore be very useful and are essential when assembling glass.

Tools:

- 2x 10mm screw-wrenches
- Knife or solid scissors
- Star screwdriver (large type)
- Flat screw-driver (large type)
- Spirit level
- Shovel
- Rope or measuring rod min. 7 meters
- Ladder (self-standing)

Tools available in all D.I.Y.-shops:

- Neutral silicone kit
- Quick-drying concrete to solidly anchor your greenhouse

Petty Facts

- Bolt slots are slots in which fits a bolt head. Nearly all profiles in this greenhouse have 1 or more bolt slots.
- In the event of bolt slot connections, always make sure that the profiles are closely pressed to one another.
- Stop bolts are bolts that we slide in a slot in preparation of further assembly; these bolts are temporarily retained by nuts at some 10cm of the profile end.
- A greenhouse consists of 2 façades (front and back), 2 sidewalls and a roof.
- Except when explicitly mentioned otherwise, short bolts (M6X10) are used.

Advice

Always use ALL detailed views as aid to align, line up and position your profile. Pay attention to section and perforations.

When fixing the nuts on the bolts, only make 2 turns; only definitively tighten the bolts and nuts after having gone through the entire page.

In case of usage of silicone, we recommend using "silirub PC". The silicone applied on the parts has a lifespan of 1 year and is best replaced regularly (you can use "sealant remover" for this). It is very important that the silicone is applied in the right conditions:

- In dry weather
- In normal temperatures (no extreme cold or heat)
- On defatted surfaces (possibly use "cleaner & degreaser")
- Allow to dry out for 1 day

Sehr geehrter Kunde!

Herzlichen Glückwunsch zu Ihrem neuen Gewächshaus! Diese Anleitung setzt keine technischen Vorkenntnisse voraus. Gehen Sie alles Schritt für Schritt durch, damit alle erforderlichen Teile in Reichweite liegen und Sie auf den nächsten Arbeitsschritt vorbereitet sind.

Sicherheit und Effizienz

Glas ist schwer, scharfkantig und zerbrechlich. Eine Leiter ist hoch und wacklig. Aluprofile sind manchmal lang und ebenfalls scharfkantig. Seien Sie vorsichtig, wenn Sie nicht täglich mit solchen Dingen arbeiten. Kinder sollten auf Abstand bleiben. Sicherheitsschuhe, eine Schutzbrille und Handschuhe können hilfreich sein. Beim Einsetzen von Glas sind sie sogar unverzichtbar.

Arbeitsmittel:

Arbeitsmittel:

- 2 Schlüssel mit 10 mm Schlüsselweite
- ein Messer oder eine robuste Schere
- Kreuzschraubendreher (groß)
- Schlitzschraubendreher (groß)
- Wasserwaage
- Spaten
- Seil oder Maßband mit einer Länge von mindestens 7 Metern
- Stehleiter

Zubehör, das Sie in jedem Baumarkt finden:

- neutrales Silikon
- schnellhärtender Beton für die Verankerung Ihres Gewächshauses

Wissenswertes

- Schraubennuten sind Nuten, in die der Kopf einer Schraube passt. Nahezu jedes Profil dieses Gewächshauses hat 1 oder mehrere Schraubennuten.
- Bei Nutverbindungen müssen die Profile immer fest aneinander gedrückt werden.
- Warteschrauben sind Schrauben, die man zur Vorbereitung der späteren Montage in eine Nut schiebt. Sie werden in etwa 10 cm Abstand zum Profilende provisorisch durch Muttern festgehalten.
- Das Gewächshaus besteht aus 2 Giebelwänden, 2 Seitenwänden und 1 Dach.
- Soweit dies nicht anders angegeben ist, werden stets kurze Schrauben (M6x10) verwendet.

Tipp

Benutzen Sie immer alle Detailansichten als Hilfsmittel für die Fluchtung, Ausrichtung und Positionierung der Profile. Beachten Sie den Querschnitt und die Bohrungen.

Die Muttern dürfen nur zwei Umdrehungen weit auf die Schrauben gedreht werden. Erst nachdem die ganze Seite mit Schrauben bestückt ist, werden alle Schrauben und Muttern endgültig festgezogen.

Verwendung von Silikon: Wir empfehlen die Verwendung von "silirub PC". Das Silikon hat eine Lebensdauer von 1 Jahr und wird am besten regelmäßig ausgetauscht (hierfür können Sie den "Sealant Remover" verwenden). Es ist sehr wichtig, dass das Silikon unter den richtigen Bedingungen angewendet wird:

- Bei trockenem Wetter
- Bei normalen Temperaturen (keine extreme Kälte oder Hitze)
- Auf entfetteten Oberflächen (evtl. "Reiniger & Entfetter" verwenden)
- 1 Tag trocknen lassen

NL:

Open alle dozen en controleer of de inhoud klopt.

Sorteer dan alle onderdelen volgens gebruik, die vermeld staat op de inhoud in de dozen. De 7 soorten van gebruik zijn :

- Gevel
- Zijwand
- Dak
- Deur
- Dakraam
- Beglazing
- Afwerking

F:

Ouvrez toutes les boîtes et assurez-vous que le contenu est correct.

Triez toutes les parties conformément à l'utilisation indiquée sur le contenu des boîtes. Les 7 types d'utilisation sont :

- Façade
- Parois
- Toit
- Porte
- Lucarne
- Vitrage
- Finition

E:

Open all the boxes and make sure the contents is correct.

Sort all parts according to the usage which is mentioned on the contents of the boxes. The 7 types of usage are :



- Facade
- side panel
- Roof
- Door
- Skylight
- Glazing
- Finishing



D:



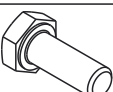

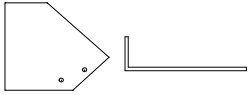
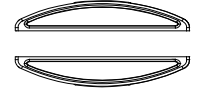
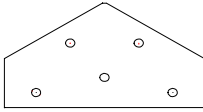

Öffnen Sie alle Boxen und kontrollieren Sie dass der Inhalt richtig ist.

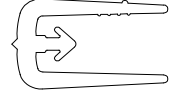

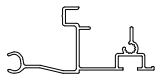
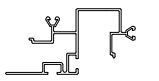
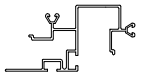

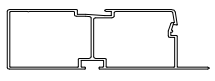
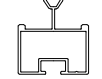
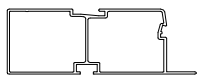
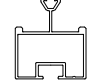
Sortieren Sie alle Teile nach der Anwendung, die auf dem Inhalt der Boxen angegeben wird. Die 7 Arten der Anwendung sind :

- Fassade
- Seitenwand
- Dach
- Tür
- Dachfenster
- Verglasung
- Finishing



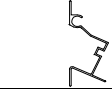
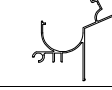
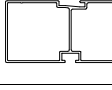
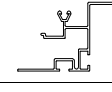
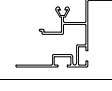
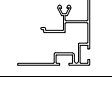
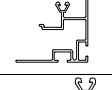
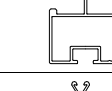

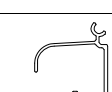

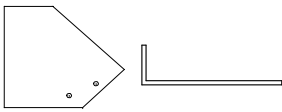
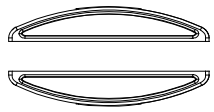
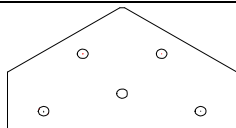
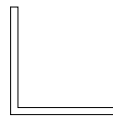
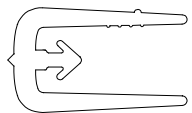

	ART.nr		Aantal	
a	800103	DIN933 M6x10		
b	800105	DIN933 M6x16		
c	800033	DIN934 M6		

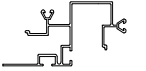
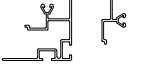



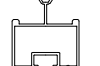

Miccolo 02 WP1		CONTENU DE LA <i>BOITE 1</i> / INHOUD VAN <i>DOOS 1</i>			Vierkante doos	
<i>art_n°</i>	<i>Qté Aantal Number Anzahl</i>	<i>F : Description NL : Beschrijving E : Description D : Beschreibung</i>	<i>Section Doorsnede Section Abschnitt</i>	<i>Longuer Lengte Length Länge</i>	<i>Utilisation Gebruik Usage Anwendung</i>	
2x 800890 2x 800899 10x 800032	1	Set plaquettes finition faïtière et fondation Set afdekplaatjes Fundering en nok Set Cover plates foundation and ridge Set Abdeckplatten Fundament und First		90	Finition Afwerking Finishing Finish	
800288	1 set	ensemble de poignées Set Handvatjes Set of handles Reihe von Griffen		150	Finition Afwerking Finishing Finish	
	1	<u>Viserie/Beslagzak/Screw Bag/Beschlägetasche Miccolo</u> 1 x 800035 afvoerpijpklem + 800040 Elleboog + 8000054 Gootafsluiter 1 x 800265 zakje dakraam + 800267 zakje deur + 800277 zakje M6x16+2vijzen 2 x 800274 zakje 40 bouten + 800275 zakje 40 moeren 3 x 800604 Voet opstecker 7 x 800106 Tirefond M6x40 + 800107 Plug 8				
800599	2	Plaquette coin pignon Hoekplaatje recht Angle plate right Winkelplatte recht		150	Pignon Gevel Facade Fassade	
800002	1	Notice Miccolo Handleiding Miccolo Instructions Miccolo Anleitung Miccolo		300		
800307	1	Ancres de coin (set = 4pcs) Hoekankers (set = 4st) Corner anchors (set = 4 pieces) Ecke Anker (Set = 4 Stück)		400	Finition Afwerking Finishing Finishing	
800296	2	Caoutchouc : 22m Rubber : 22m Caoutchouc : 22m Gummi : 22m		450	Vitrage Beglazing Glazing Verglasung	

Miccolo 02	CONTENU DE LA BOITE 2 / INHOUD VAN DOOS 2			Doos 1,7 m	
	CONTENT BOX 2 / Inhalt BOX 2				
art_n°	Qté Aantal Number Anzahl	F : Description NL : Beschrijving E : Description D : Beschreibung	Section Doorsnede Section Abschnitt	Longuer Lengte Length Länge	Utilisation Gebruik Usage Anwendung
800089	2	Profilé horizontale de la lucarne Horizontaal dakraamprofiel Horizontal skylight profile horizontale Dachprofil		757	Lucarne Dakraam Skylight Dachfenster
800602	1	Profilé du pignon du toit côté GAUCHE Hoekprofiel Dak LINKS Angle Profile roof LEFT Winkelprofil Dach LINKS		808	Pignon Gevel Facade Fassade
800603	1	Profilé du pignon du toit côté DROITE Hoekprofiel Dak RECHTS Angle Profile roof RECHTS Winkelprofil Dach LINKS		808	Pignon Gevel Facade Fassade
800038	2	Profilé verticale de la lucarne Verticaal dakraamprofiel Vertical skylight profile Vertikale Dachprofil		770	Lucarne Dakraam Skylight Dachfenster
800564	1	Fondation du pignon Gauche (+ 2 barres verticales L=707) Fundering gevel Links (+ 2 glasregels L=707) Foundation facade Left (+ 2 glass lines L=707) Grundmauer Fassade Links (+ 2 Glasdachlinien L=707)		768	Pignon Gevel Facade Fassade
800252	3	Traverse de la lucarne Dwarsligger dakraam Cross bar skylight überquerbar Dachfenster		707	Lucarne Dakraam Skylight Dachfenster
800565	1	Fondation du pignon Droite (+ 2 barres verticales L=802+707) Fundering gevel Rechts (+ 2 glasregels L=802+707) Foundation facade Right (+ 2 glass lines L=802+707) Grundmauer Fassade Rechts (+ 2 Glasdachlinien L=802+707)		768	Pignon Gevel Facade Fassade
800831	1	Barre verticale du toit Glasregel Dak Glass roof line Glasdachlinie		808	Toit Dak Roof Dach
800272	1	Tige d'ouverture de la lucarne Opsteker dakraam Attachable ring skylight Aufsteckring		660	Lucarne Dakraam Skylight Dachfenster
800123	1	Tube PVC Afvoerpijp PVC Waste pipe PVC Abflussrohr PVC		1000	Finition Afwerking Finishing Finish
800073	1	Profilé horizontale de la porte Horizontaal deurprofiel Horizontal door profile Horizontale Türprofil		708	La Porte Deur Door Tür
800012	1	Profilé horizontale de la porte avec autocollant Horizontaal deurprofiel met sticker Horizontal door profile with sticker Horizontale Türprofil mit Aufkleber		708	La Porte Deur Door Tür



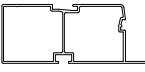
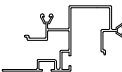
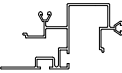
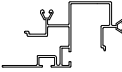
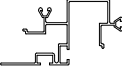





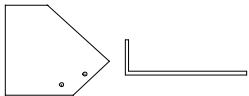
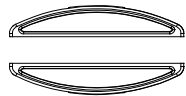
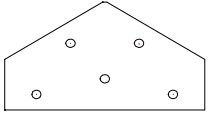
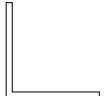
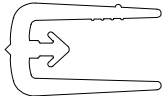

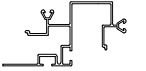
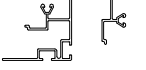
Miccolo 02		BOX 3 - Contents Client				<i>Dozen</i> <i>1,7m + 1m</i>
<i>art_n°</i>	<i>Number / Anzahl</i>	<i>F : Description</i>	<i>NL : Beschrijving</i>	<i>Section / Doorsnede</i>	<i>Longuer / Lengte(mm)</i>	<i>Utilisation / Gebruik</i>
		<i>E : Description</i>	<i>D : Beschreibung</i>	<i>Section / Abschnitt</i>	<i>Length / Länge</i>	<i>Usage / Anwendung</i>
801530	1	Faîtière Muurnok Ridge Kamm			1504	Toit Dak Roof Dach
800322	1	Gauttière Goot MET Rail Gutter Dachrinne			1504	Parois Zijwand Side panel Seitenwand
803598	1	Fondation du parois Fundering zijwand Foundation for side wall Grundmauer für Seitenwand			1504	Parois Zijwand Side panel Seitenwand
800453	1	Profilé du pignon côté GAUCHE Hoekprofiel Gevel zijwand LINKS Angle profile side wall LEFT Winkelprofil Seitenwand LINKS			1655	Pignon Gevel Facade Fassade
800454	1	Profilé du pignon côté DROITE Hoekprofiel Gevel zijwand RECHTS Angle profile side wall RIGHT Winkelprofil Seitenwand RECHTS			1655	Pignon Gevel Facade Fassade
800566	1	Profilé du mur côté GAUCHE Hoekprofiel Muur zijwand LINKS Angle profile side wall LEFT Winkelprofil Seitenwand LINKS			2055	Pignon Gevel Facade Fassade
800567	1	Profilé du pignon côté DROITE Hoekprofiel Gevel zijwand RECHTS Angle profile side wall RIGHT Winkelprofil Seitenwand RECHTS			2055	Pignon Gevel Facade Fassade
800077	1	Barre verticale du pignon Glasregel Gevel Glas line facade Glasslinie Fassade			1643	Pignon Gevel Facade Fassade
800256	2	Profilé verticale de la porte coullisante Verticaal deurprofiel Vertical door profile Vertikaler Türprofil			1612	La Porte Deur Door Tür
800452 (WP2)	2	Tirand du toit Treklat Dak Pull bar roof Ziehlatte Dach			1794	Toit Dak Roof Dach
800257	1	Profilé clique de la porte coullisante Clickprofiel deur Click profile door Klickprofil Tür			1485	La Porte Deur Door Tür
800262	1	Profilé U de la porte coullissante Onderloopregel deur Undergo rule door Unterlaufbar Tür			1475	La Porte Deur Door Tür



Miccolo 03		<u>CONTENU DE LA BOITE 1</u> / <u>INHOUD VAN DOOS 1</u>			Vierkante doos	
art_n°	<i>Qté</i> <i>Aantal</i> <i>Number</i> <i>Anzahl</i>	<i>F : Description</i> <i>NL : Beschrijving</i> <i>E : Description</i> <i>D : Beschreibung</i>	<i>Section</i> <i>Doorsnede</i> <i>Section</i> <i>Abschnitt</i>	<i>Longuer</i> <i>Lengte</i> <i>Length</i> <i>Länge</i>	<i>Utilisation</i> <i>Gebruik</i> <i>Usage</i> <i>Anwendung</i>	
2x 800890 2x 800899 10x 800032	1	Set plaquettes finition faïtière et fondation Set afdekplaatjes Fundering en nok Set Cover plates foundation and ridge Set Abdeckplatten Fundament und First		90	Finition Afwerking Finishing Finish	
800288	1 set	ensemble de poignées Set Handvatjes Set of handles Reihe von Griffen		150	Finition Afwerking Finishing Finish	
	1	<u>Viserie/Beslagzak/Screw Bag/Beschlägetasche Miccolo</u> 1 x 800035 afvoerpijpklem + 800040 Elleboog + 8000054 Gootafsluiter 1 x 800265 zakje dakraam + 800267 zakje deur + 800277 zakje M6x16+2vijzen 2 x 800274 zakje 40 bouten + 800275 zakje 40 moeren 3 x 800604 Voet opsteker 8 x 800106 Tirefond M6x40 + 800107 Plug 8				
800599	2	Plaquette coin pignon Hoekplaatje recht Angle plate right Winkelplatte recht		150	Pignon Gevel Facade Fassade	
800002	1	Notice Miccolo Handleiding Miccolo Instructions Miccolo Anleitung Miccolo		300		
800307	1	Ancres de coin (set = 4pcs) Hoekankers (set = 4st) Corner anchors (set = 4 pieces) Ecke Anker (Set = 4 Stück)		400	Finition Afwerking Finishing Finishing	
800296	2	Caoutchouc : 22m Rubber : 22m Caoutchouc : 22m Gummi : 22m		450	Vitrage Beglazing Glazing Verglasung	

Miccolo 03	CONTENU DE LA BOITE 2 / INHOUD VAN DOOS 2				Doos 1,7 m
	CONTENT BOX 2		Inhalt BOX 2		
art_n°	Qté Aantal Number Anzahl	F : Description NL : Beschrijving E : Description D : Beschreibung	Section Doorsnede Section Abschnitt	Longuer Lengte Length Länge	Utilisation Gebruik Usage Anwendung
800089	2	Profilé horizontale de la lucarne Horizontaal dakraamprofiel Horizontal skylight profile horizontale Dachprofil		757	Lucarne Dakraam Skylight Dachfenster
800602	1	Profilé du pignon du toit côté GAUCHE Hoekprofiel Dak LINKS Angle Profile roof LEFT Winkelprofil Dach LINKS		808	Pignon Gevel Facade Fassade
800603	1	Profilé du pignon du toit côté DROITE Hoekprofiel Dak RECHTS Angle Profile roof RECHTS Winkelprofil Dach LINKS		808	Pignon Gevel Facade Fassade
800038	2	Profilé verticale de la lucarne Verticaal dakraamprofiel Vertical skylight profile Vertikale Dachprofil		770	Lucarne Dakraam Skylight Dachfenster
800252	3	Traverse de la lucarne Dwarsligger dakraam Cross bar skylight überquerbar Dachfenster		707	Lucarne Dakraam Skylight Dachfenster
800272	1	Tige d'ouverture de la lucarne Opsteker dakraam Attachable ring skylight Aufsteckring		660	Lucarne Dakraam Skylight Dachfenster
800123	1	Tube PVC Afvoerpijp PVC Waste pipe PVC Abflussrohr PVC		1000	Finition Afwerking Finishing Finish
800073	1	Profilé horizontale de la porte Horizontaal deurprofiel Horizontal door profile Horizontale Türprofil		708	La Porte Deur Door Tür
800012	1	Profilé horizontale de la porte avec autocollant Horizontaal deurprofiel met sticker Horizontal door profile with sticker Horizontale Türprofil mit Aufkleber		708	La Porte Deur Door Tür
800564	1	Fondation du pignon Gauche (+ 2 barres verticales L=707) Fundering gevel Links (+ 2 glasregels L=707) Foundation facade Left (+ 2 glass linesL=707) Grundmauer Fassade Links (+ 2 Glasdachlinies L=707)		768	Pignon Gevel Facade Fassade
800565	1	Fondation du pignon Droite (+ 2 barres verticales L=802) Fundering gevel Rechts (+ 2 glasregels L=802) Foundation facade Right (+ 2 glass linesL=802) Grundmauer Fassade Rechts (+ 2 Glasdachlinies L=802)		768	Pignon Gevel Facade Fassade
800831	2	Barre verticale du toit Glasregel Dak Glass roof line Glasdachlinie		808	Toit Dak Roof Dach

Miccolo 03 WP6+4+2	BOX 3 - Contents Client				Dozen 1,7m + 1m	
art_n°	Qté / Aantal Number / Anzahl	F : Description E : Description	NL : Beschrijving D : Beschreibung	Section / Doorsnede Section / Abschnitt	Longuer / Lengte(mm) Length / Länge	Utilisation / Gebruik Usage / Anwendung
801520	1	Faîtière Muurnok Ridge Kamm			2243	Toit Dak Roof Dach
800228	1	Gouttière Goot MET Rail Gutter Dachrinne			2243	Parois Zijwand Side panel Seitenwand
803628	1	Fondation du parois Fundering zijwand Foundation for side wall Grundmauer für Seitenwand			2243	Parois Zijwand Side panel Seitenwand
800453	1	Profilé du pignon côté GAUCHE Hoekprofiel Gevel zijwand LINKS Angle profile side wall LEFT Winkelprofil Seitenwand LINKS			1655	Pignon Gevel Facade Fassade
800454	1	Profilé du pignon côté DROITE Hoekprofiel Gevel zijwand RECHTS Angle profile side wall RIGHT Winkelprofil Seitenwand RECHTS			1655	Pignon Gevel Facade Fassade
800566	1	Profilé du mur côté GAUCHE Hoekprofiel Muur zijwand LINKS Angle profile side wall LEFT Winkelprofil Seitenwand LINKS			2055	Pignon Gevel Facade Fassade
800567	1	Profilé du pignon côté DROITE Hoekprofiel Gevel zijwand RECHTS Angle profile side wall RIGHT Winkelprofil Seitenwand RECHTS			2055	Pignon Gevel Facade Fassade
800256	2	Profilé verticale de la porte coullisante Verticaal deurprofiel Vertical door profile Vertikaler Türprofil			1612	La Porte Deur Door Tür
800257	1	Profilé clique de la porte coullisante Clickprofiel deur Click profile door Klickprofil Tür			1485	La Porte Deur Door Tür
800452	2	Tirand du toit Treklat Dak Pull bar roof Ziehlatte Dach			1794	Toit Dak Roof Dach
800262	1	Profilé U de la porte coullissante Onderloopregel deur Undergo rule door Unterlaufbar Tür			1475	La Porte Deur Door Tür

Miccolo 04		CONTENU DE LA <i>BOITE 1</i> / INHOUD VAN <i>DOOS 1</i>			Vierkante doos	
art_n°	<i>Qté</i> <i>Aantal</i> <i>Number</i> <i>Anzahl</i>	<i>F : Description</i> <i>NL : Beschrijving</i> <i>E : Description</i> <i>D : Beschreibung</i>	<i>Section</i> <i>Doorsnede</i> <i>Section</i> <i>Abschnitt</i>	<i>Longuer</i> <i>Lengte</i> <i>Length</i> <i>Länge</i>	<i>Utilisation</i> <i>Gebruik</i> <i>Usage</i> <i>Anwendung</i>	
2x 800890 2x 800899 10x 800032	1	Set plaquettes finition faïtière et fondation Set afdekplaatjes Fundering en nok Set Cover plates foundation and ridge Set Abdeckplatten Fundament und First		90	Finition Afwerking Finishing Finish	
800288	1 set	ensemble de poignées Set Handvatjes Set of handles Reihe von Griffen		150	Finition Afwerking Finishing Finish	
	1	<u>Viserie/Beslagzak/Screw Bag/Beschlägetasche Miccolo</u> 1 x 800035 afvoerpijpklem + 800040 Elleboog + 8000054 Gootafsluiter 1 x 800265 zakje dakraam + 800267 zakje deur + 800277 zakje M6x16+2vijzen 2 x 800274 zakje 40 bouten + 800275 zakje 40 moeren 3 x 800604 Voet opstecker 9 x 800106 Tirefond M6x40 + 800107 Plug 8				
800599	2	Plaquette coin pignon Hoekplaatje recht Angle plate right Winkelplatte recht		150	Pignon Gevel Facade Fassade	
800002	1	Notice Miccolo Handleiding Miccolo Instructions Miccolo Anleitung Miccolo		300		
800307	1	Ancre de coin (set = 4pcs) Hoekankers (set = 4st) Corner anchors (set = 4 pieces) Ecke Anker (Set = 4 Stück)		400	Finition Afwerking Finishing Finishing	
800296	2	Caoutchouc : 22m Rubber : 22m Caoutchouc : 22m Gummi : 22m		450	Vitrage Beglazing Glazing Verglasung	

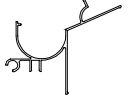
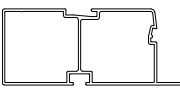
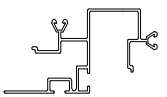
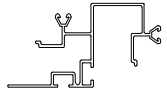
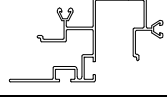
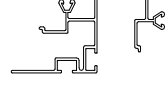
Miccolo 04	CONTENU DE LA BOITE 2 / INHOUD VAN DOOS 2			Doos 1,7 m	
	CONTENT BOX 2 / Inhalt BOX 2				
art_n°	Qté Aantal Number Anzahl	F : Description NL : Beschrijving E : Description D : Beschreibung	Section Doorsnede Section Abschnitt	Longuer Lengte Length Länge	Utilisation Gebruik Usage Anwendung
800089	2	Profilé horizontale de la lucarne Horizontaal dakraamprofiel Horizontal skylight profile horizontale Dachprofil		757	Lucarne Dakraam Skylight Dachfenster
800602	1	Profilé du pignon du toit côté GAUCHE Hoekprofiel Dak LINKS Angle Profile roof LEFT Winkelprofil Dach LINKS		808	Pignon Gevel Facade Fassade
800603	1	Profilé du pignon du toit côté DROITE Hoekprofiel Dak RECHTS Angle Profile roof RECHTS Winkelprofil Dach LINKS		808	Pignon Gevel Facade Fassade
800038	2	Profilé verticale de la lucarne Verticaal dakraamprofiel Vertical skylight profile Vertikale Dachprofil		770	Lucarne Dakraam Skylight Dachfenster
800252	3	Traverse de la lucarne Dwarsligger dakraam Cross bar skylight überquerbar Dachfenster		707	Lucarne Dakraam Skylight Dachfenster
800272	1	Tige d'ouverture de la lucarne Opsteker dakraam Attachable ring skylight Aufsteckring		660	Lucarne Dakraam Skylight Dachfenster
800123	1	Tube PVC Afvoerpijp PVC Waste pipe PVC Abflussrohr PVC		1000	Finition Afwerking Finishing Finish
800073	1	Profilé horizontale de la porte Horizontaal deurprofiel Horizontal door profile Horizontale Türprofil		708	La Porte Deur Door Tür
800012	1	Profilé horizontale de la porte avec autocollant Horizontaal deurprofiel met sticker Horizontal door profile with sticker Horizontale Türprofil mit Aufkleber		708	La Porte Deur Door Tür
800564	1	Fondation du pignon Gauche (+ 2 barres verticales L=707 + 802) Fundering gevel Links (+ 2 glasregels L=707 + 802) Foundation facade Left (+ 2 glass lines L=707 + 802) Grundmauer Fassade Links (+ 2 Glasdachlinies L=707 + 802)		768	Pignon Gevel Facade Fassade
800565	1	Fondation du pignon Droite (+ 2 barres verticales L=802) Fundering gevel Rechts (+ 2 glasregels L=802) Foundation facade Right (+ 2 glass lines L=802) Grundmauer Fassade Rechts (+ 2 Glasdachlinies L=802)		768	Pignon Gevel Facade Fassade
800831	3	Barre verticale du toit Glasregel Dak Glass roof line Glasdachlinie		808	Toit Dak Roof Dach

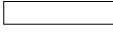
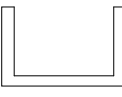
Miccolo 04 WP4 + 2 + 6	BOX 3 - Contents Client					Doos 3m
art_n°	Qté / Aantal Number / Anzahl	F : Description E : Description	NL : Beschrijving D : Beschreibung	Section / Doorsnede Section / Abschnitt	Longuer / Lengte(mm) Length / Länge	Utilisation / Gebruik Usage / Anwendung
801521	1	Faîtière Muurnok Ridge Kamm			2981	Toit Dak Roof Dach
800334	1	Gauttière Goot MET Rail Gutter Dachrinne			2981	Parois Zijwand Side panel Seitenwand
800042	1	Fondation du parois (+ 2 barres verticales L=1643) Fundering zijwand (+ 2 glasregels L=1643) Foundation for side wall (+ 2 glass lines L=1643) Grundmauer für Seitenwand (+ 2 Glasdachlinien L=1643)			2981	Parois Zijwand Side panel Seitenwand
800453	1	Profilé du pignon côté GAUCHE Hoekprofiel Gevel zijwand LINKS Angle profile side wall LEFT Winkelprofil Seitenwand LINKS			1655	Pignon Gevel Facade Fassade
800454	1	Profilé du pignon côté DROITE Hoekprofiel Gevel zijwand RECHTS Angle profile side wall RIGHT Winkelprofil Seitenwand RECHTS			1655	Pignon Gevel Facade Fassade
800566	1	Profilé du mur côté GAUCHE Hoekprofiel Muur zijwand LINKS Angle profile side wall LEFT Winkelprofil Seitenwand LINKS			2055	Pignon Gevel Facade Fassade
800567	1	Profilé du pignon côté DROITE Hoekprofiel Gevel zijwand RECHTS Angle profile side wall RIGHT Winkelprofil Seitenwand RECHTS			2055	Pignon Gevel Facade Fassade
800256	2	Profilé verticale de la porte coullisante Verticaal deurprofiel Vertical door profile Vertikaler Türprofil			1612	La Porte Deur Door Tür
800452 (WP 2)	2	Tirand du toit Treklat Dak Pull bar roof Ziehlatte Dach			1794	Toit Dak Roof Dach
800262	1	Profilé U de la porte coullissante Onderloopregel deur Undergo rule door Unterlaufbar Tür			1475	La Porte Deur Door Tür

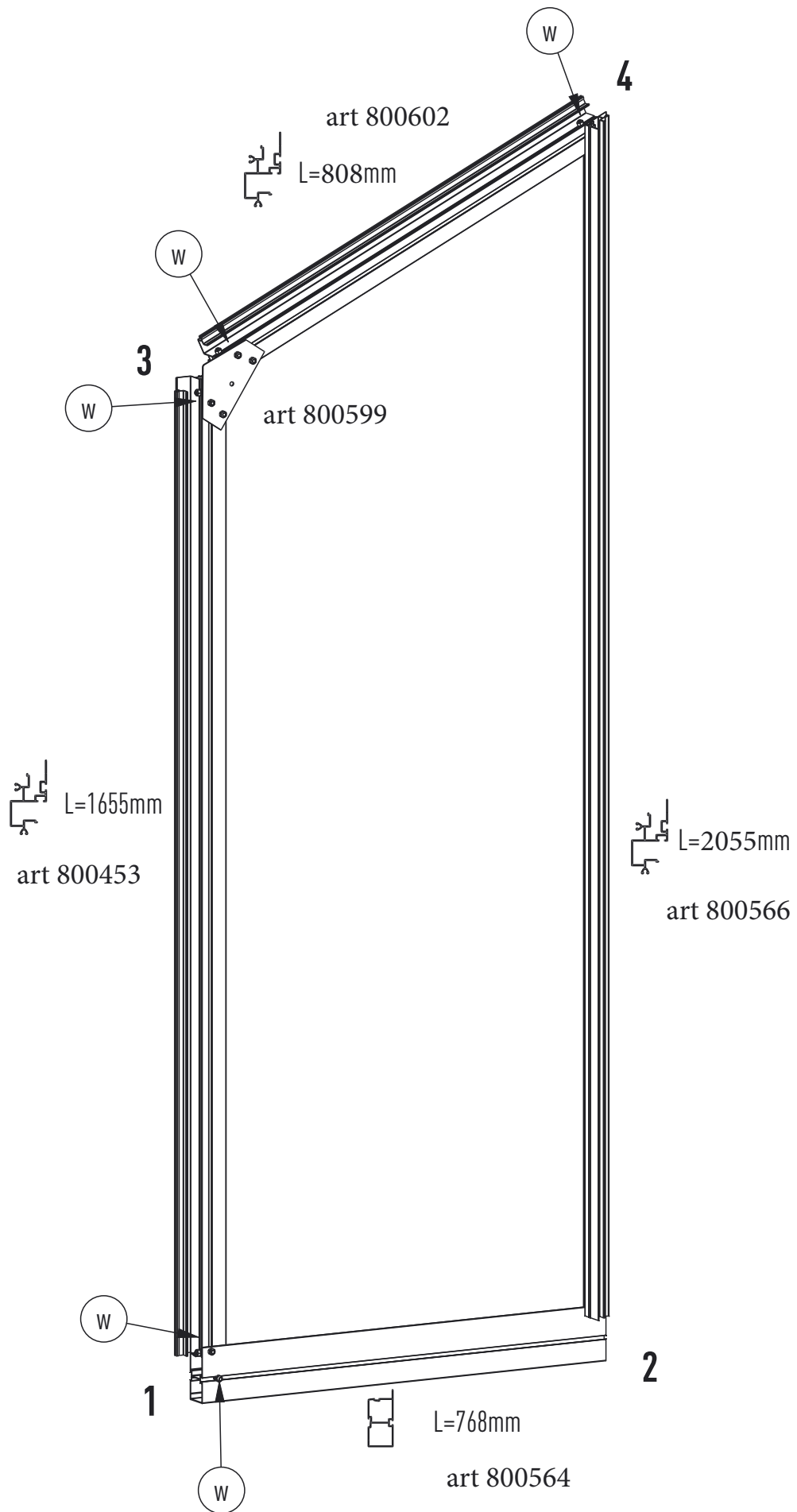
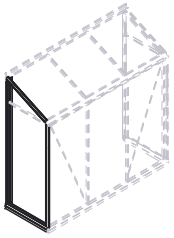

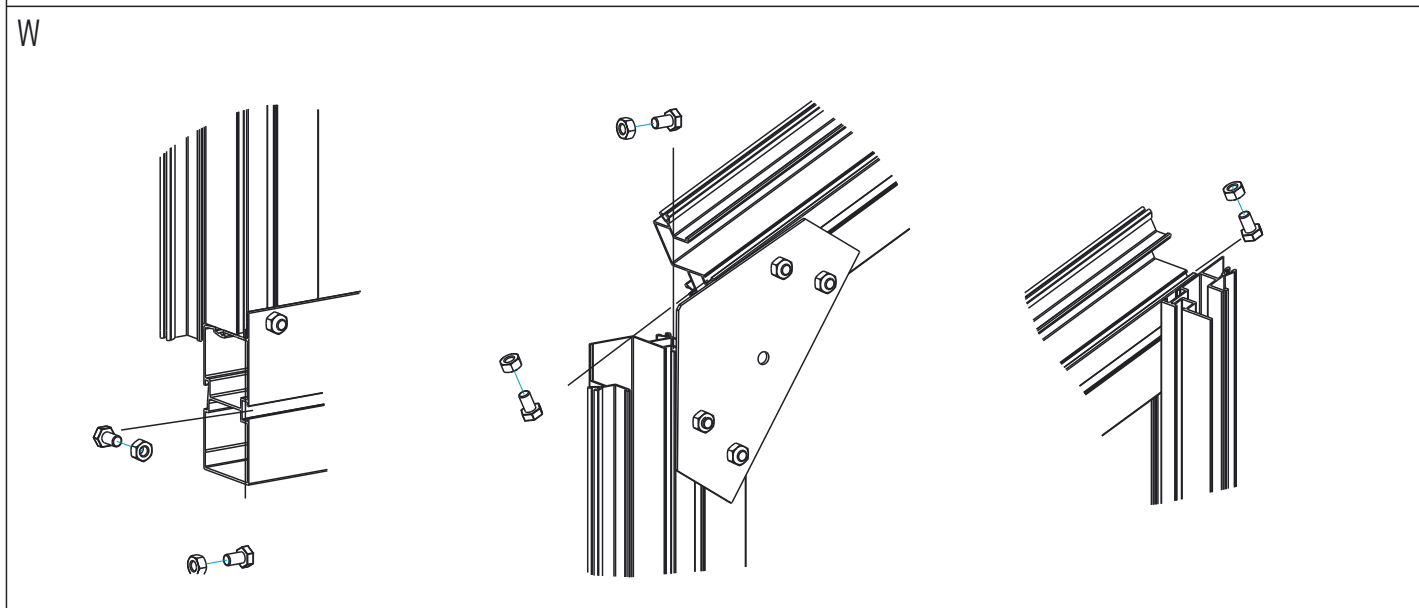
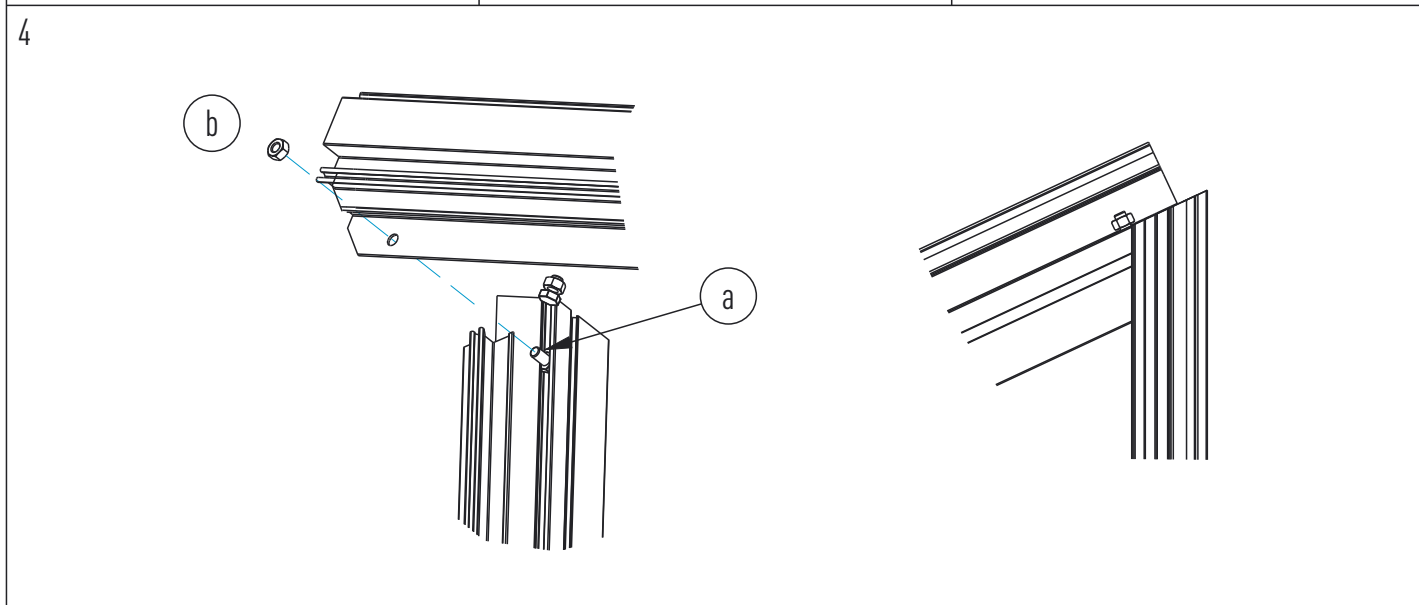
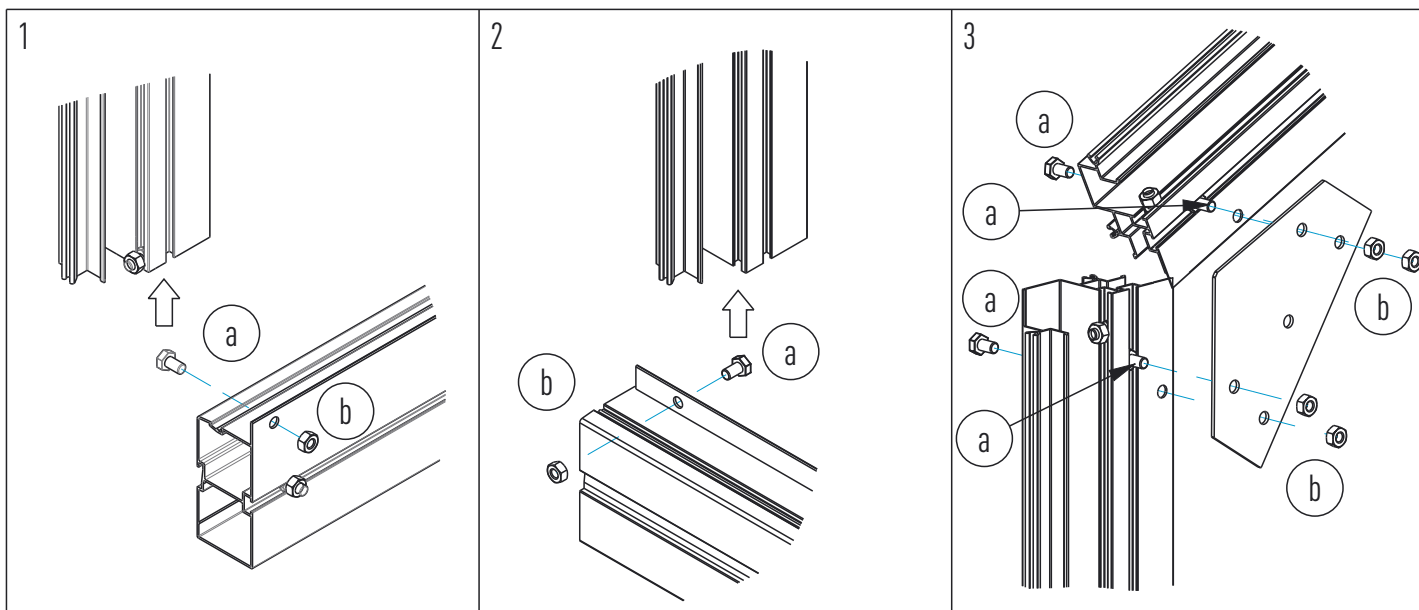
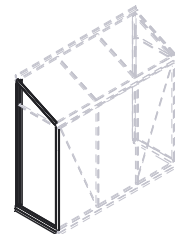

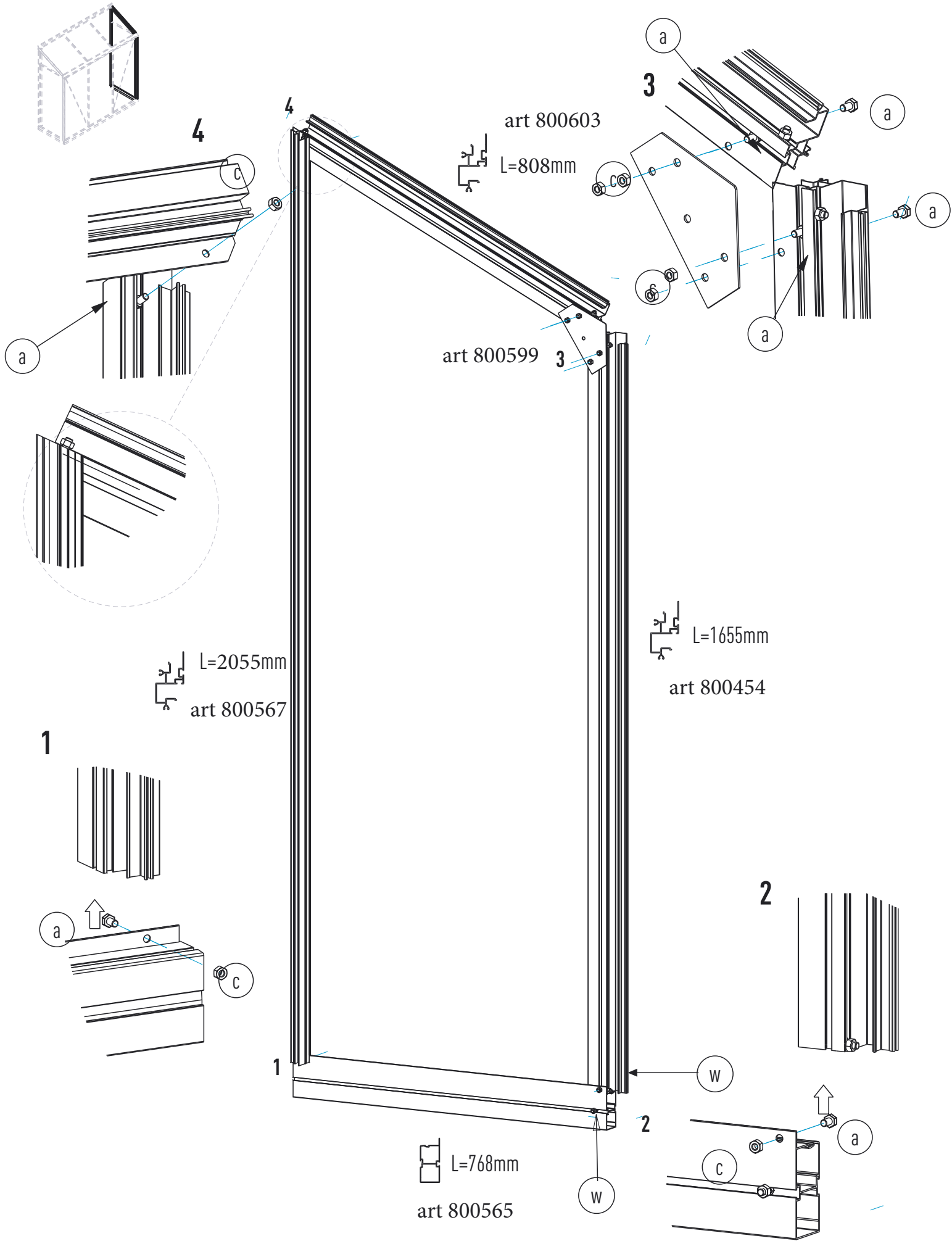

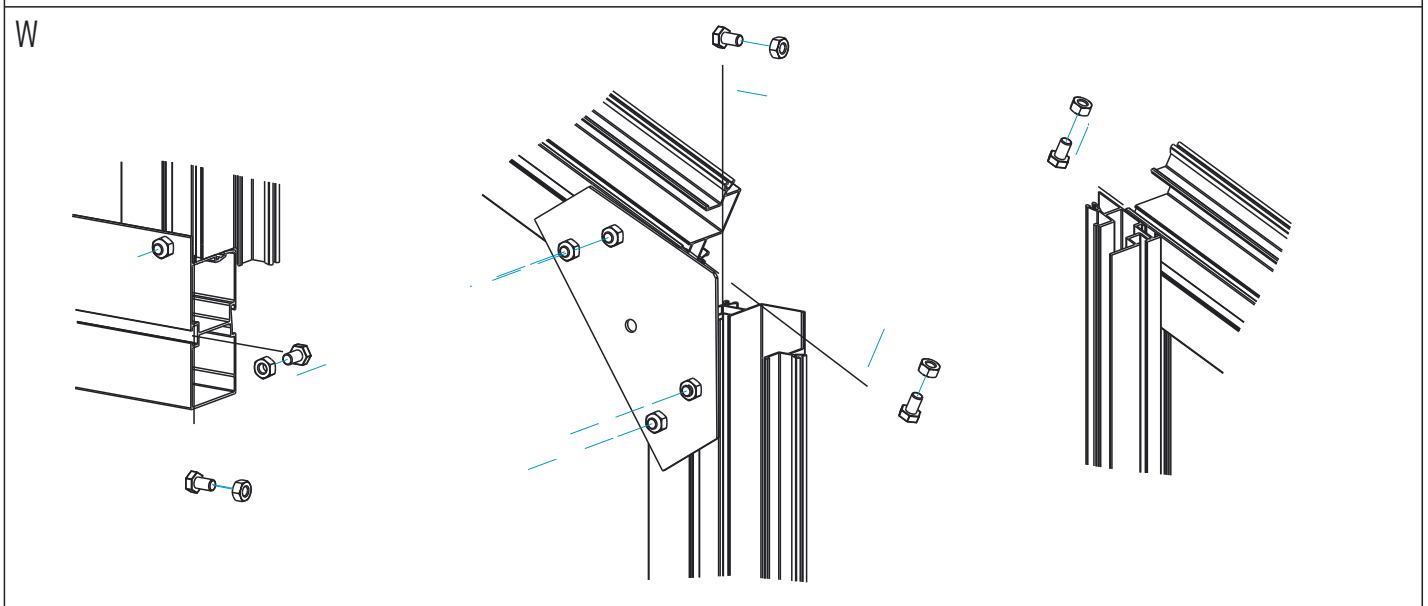
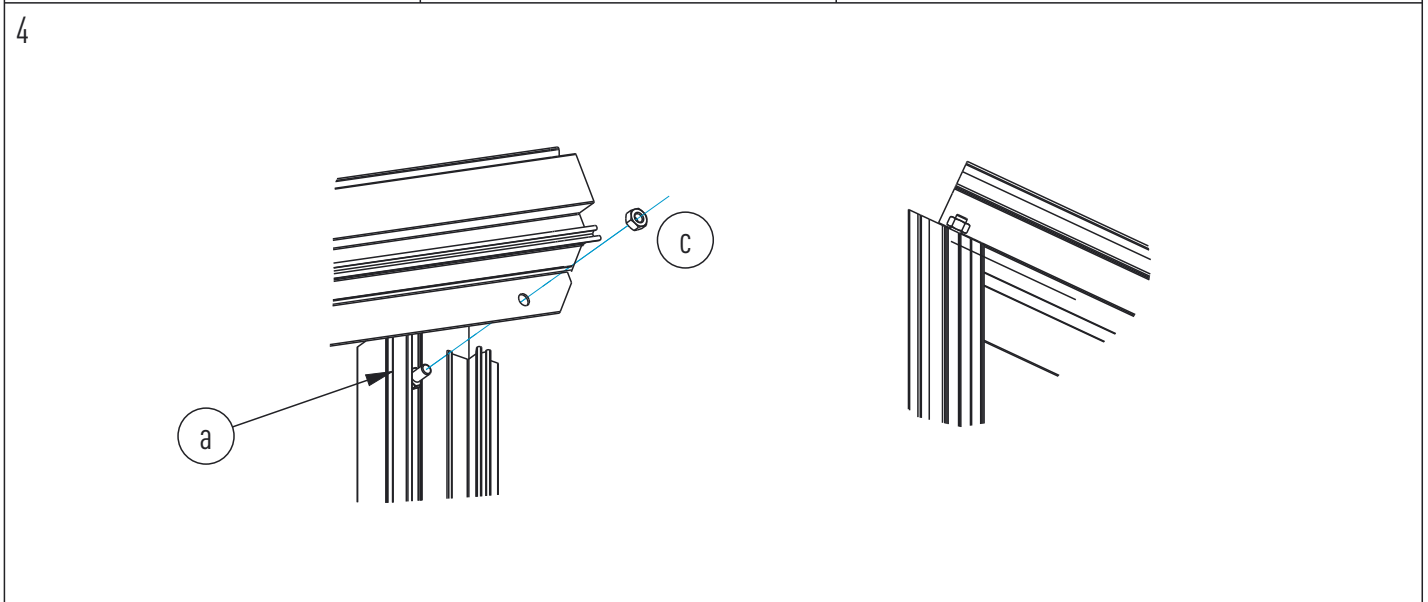
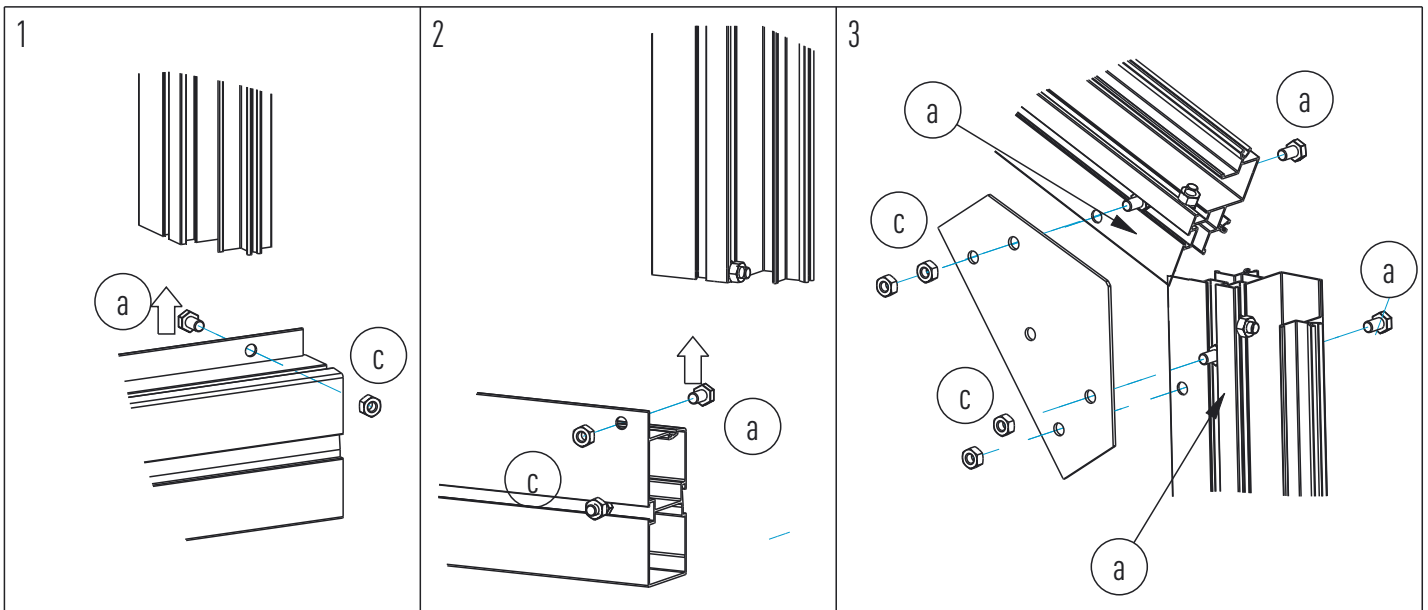
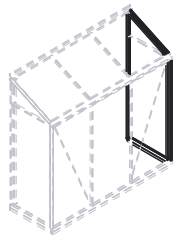

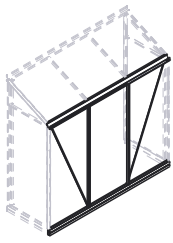

 L=1504mm art 800322

2R

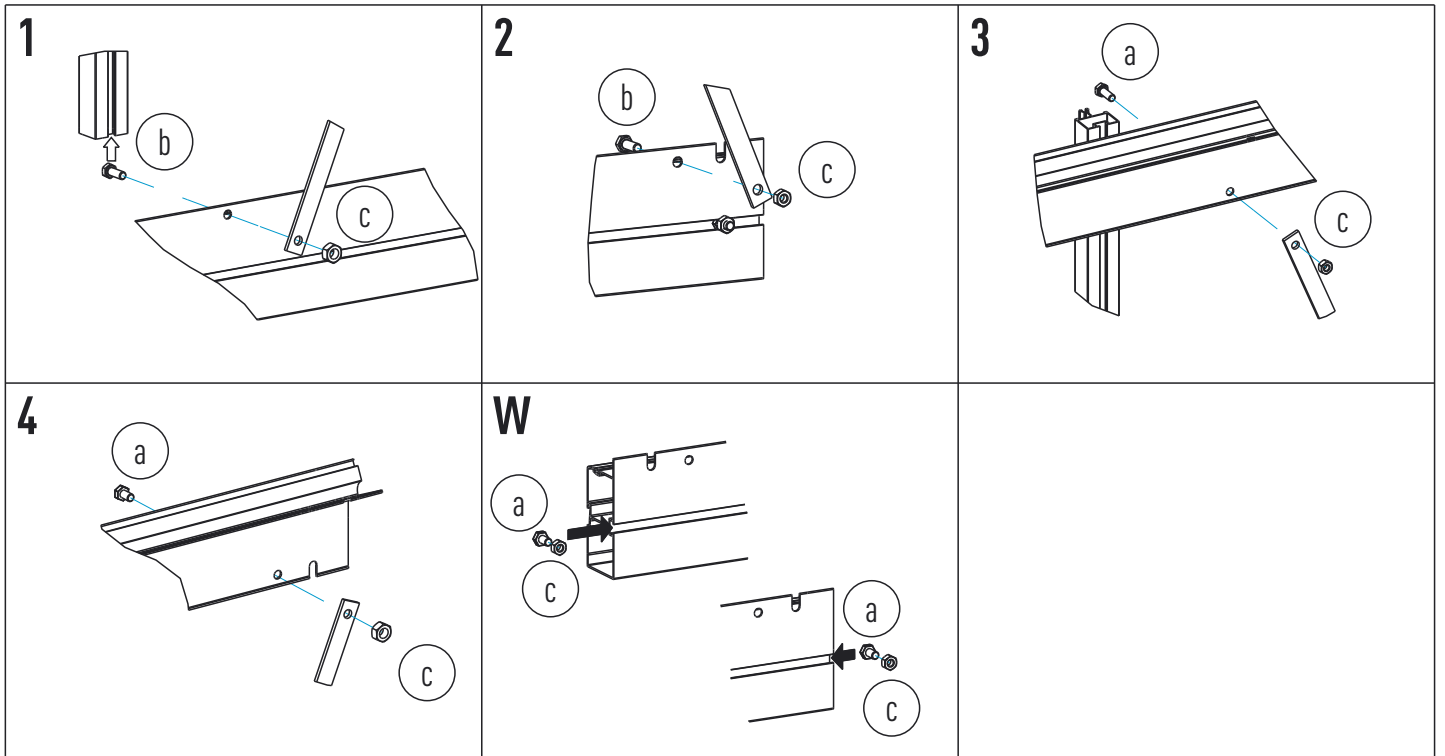
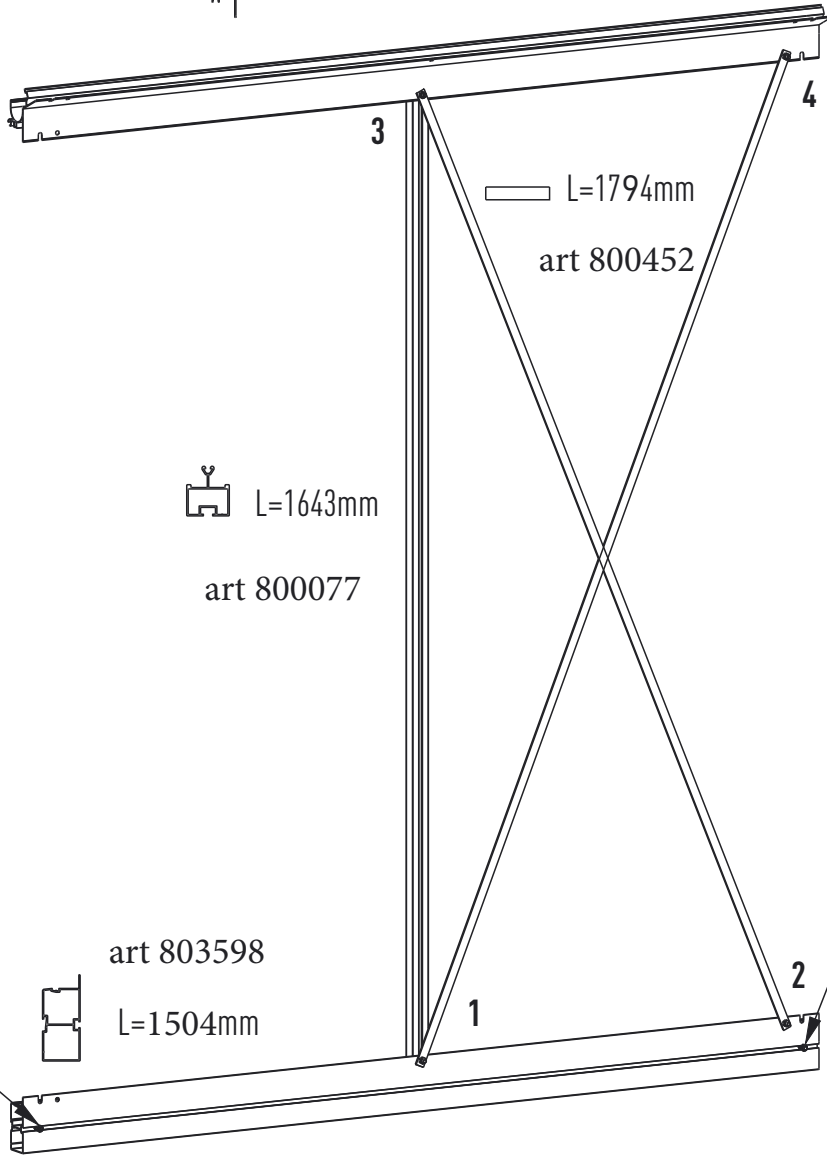

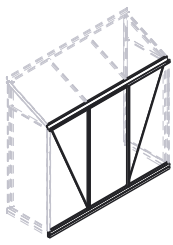

art 800228

3R

 L=2243mm

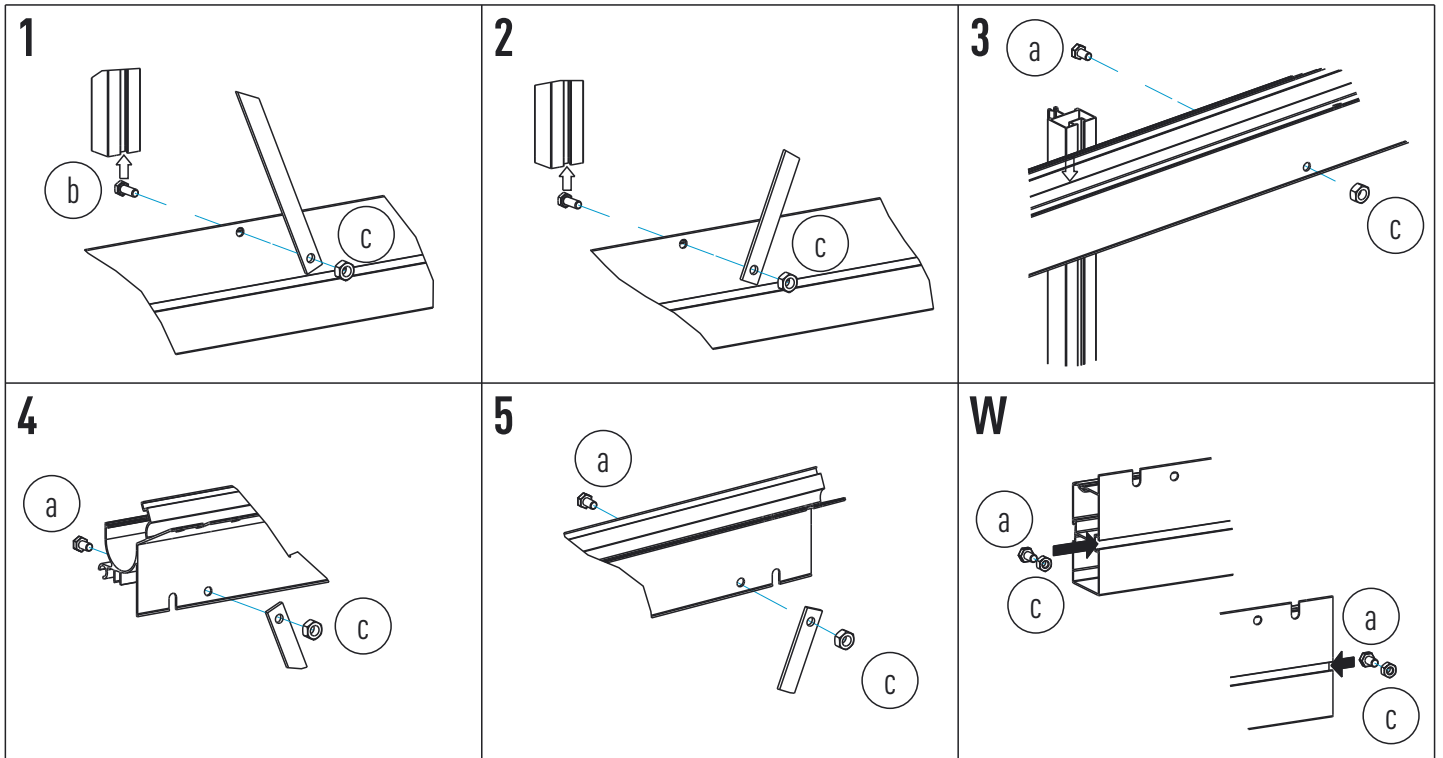
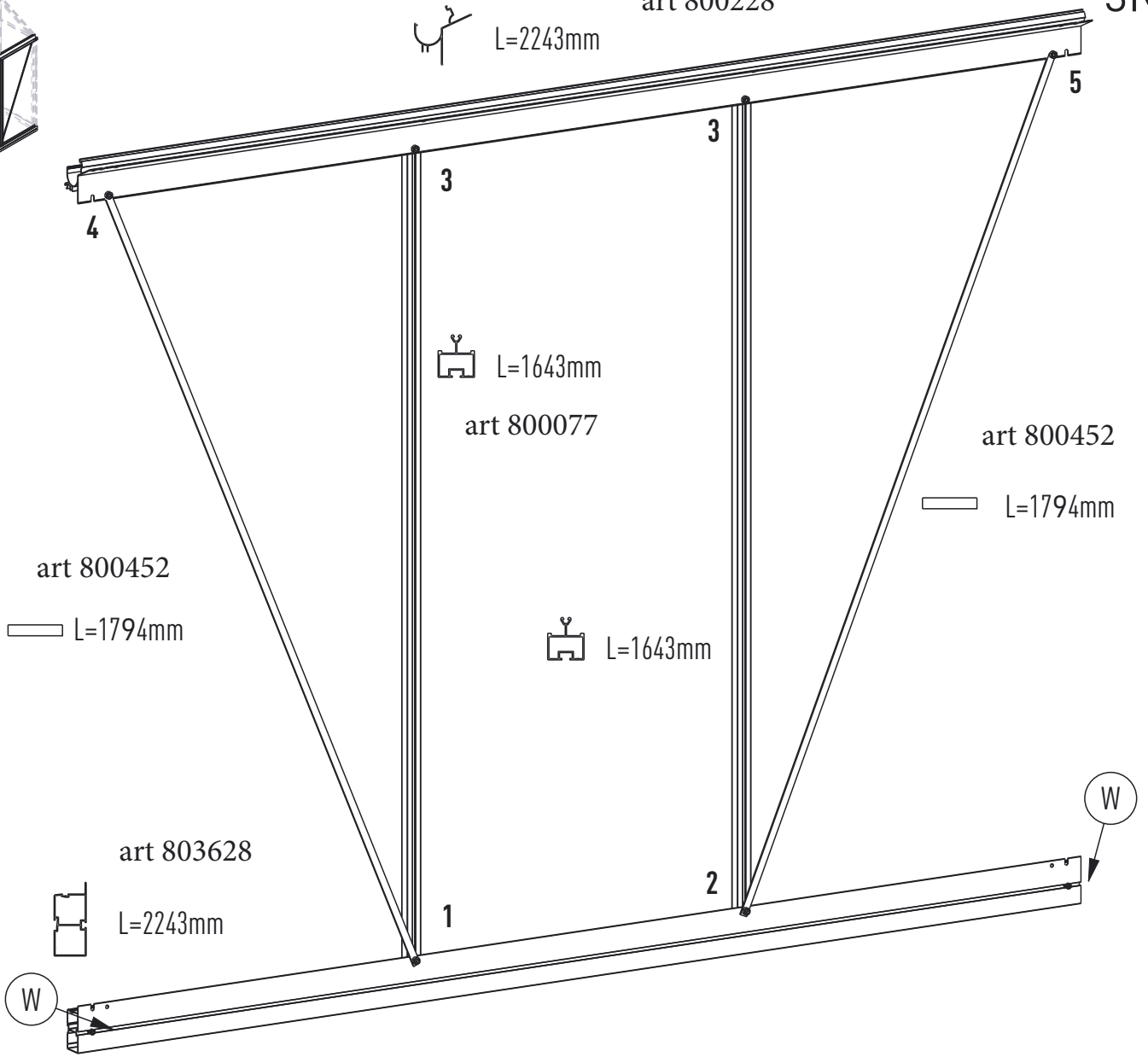

art 800334

L=2981mm

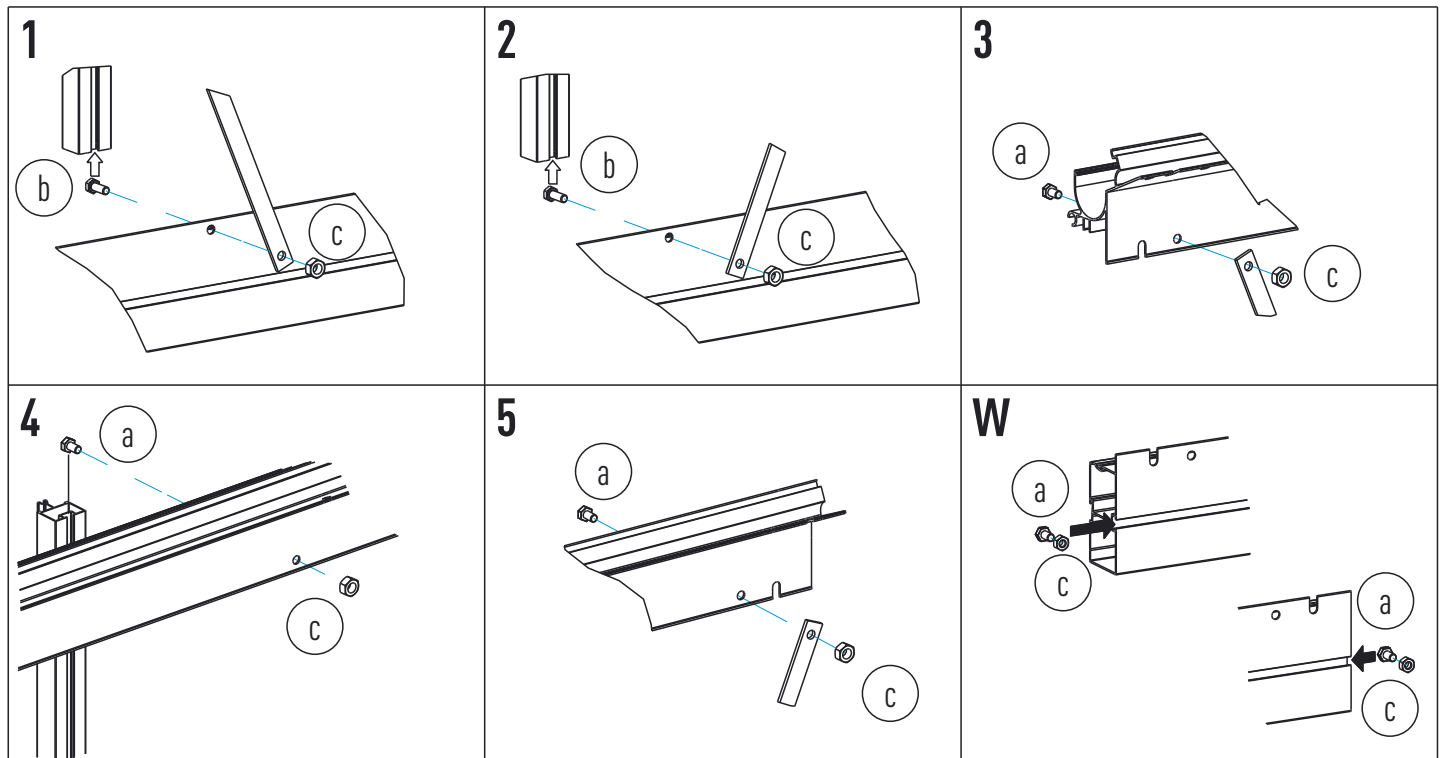
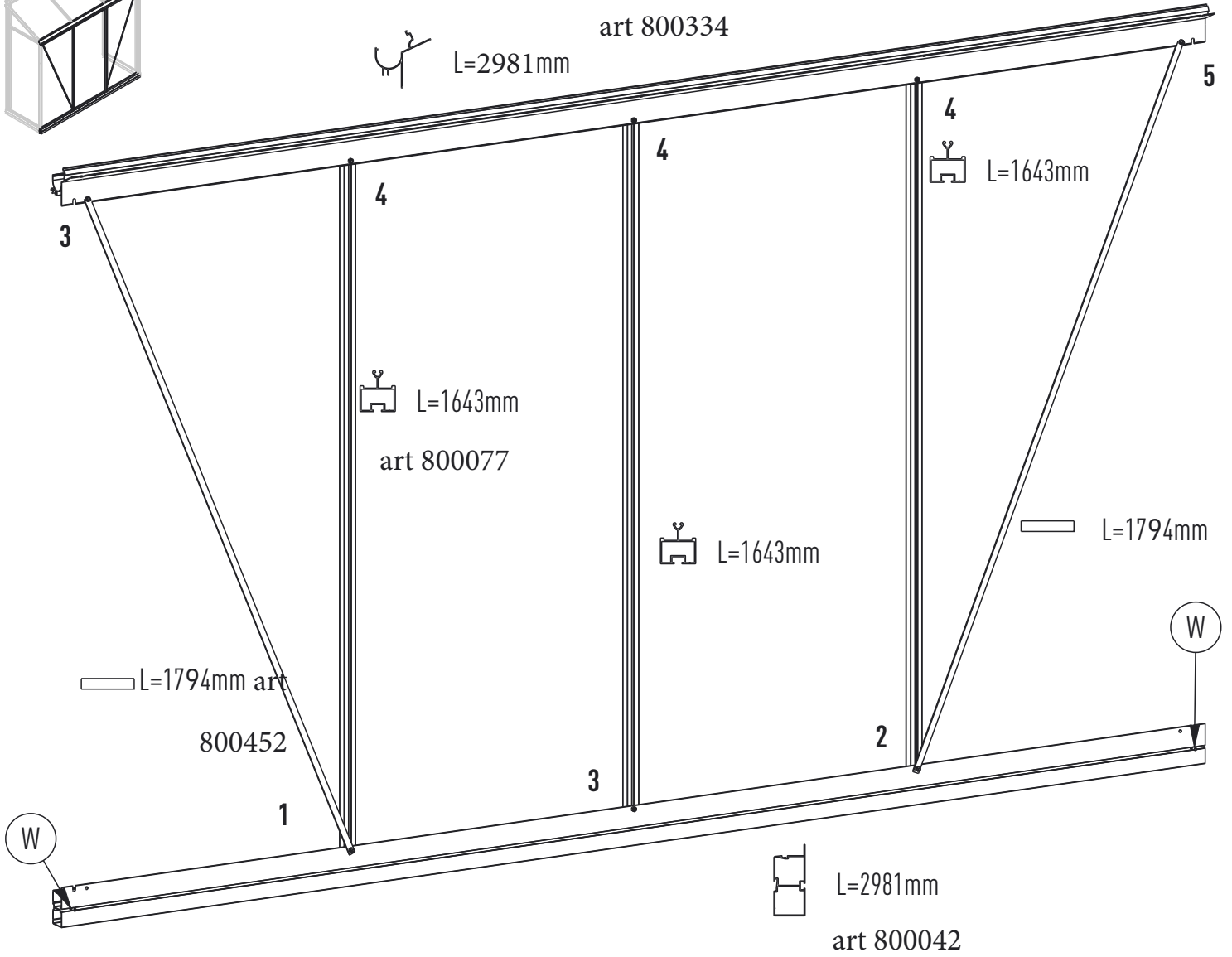
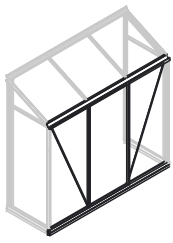

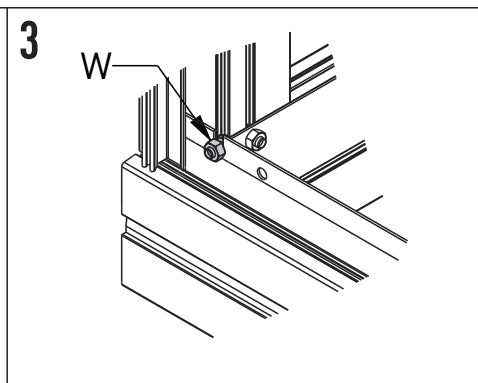
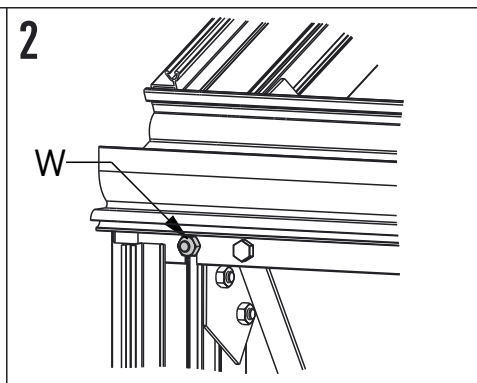
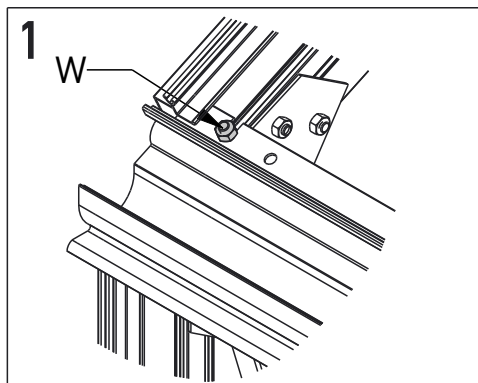
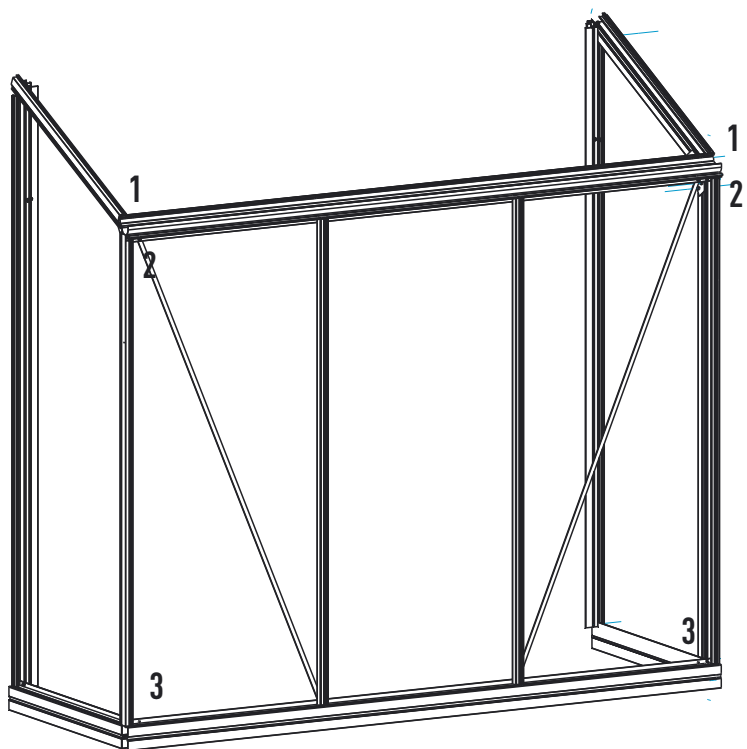
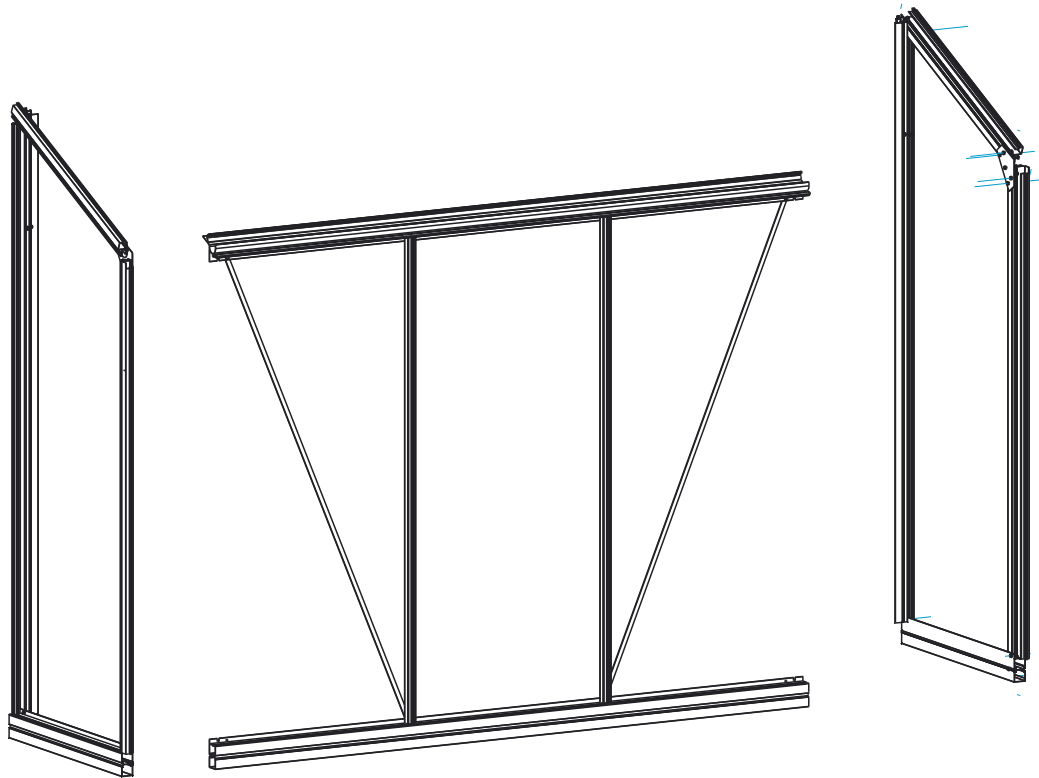

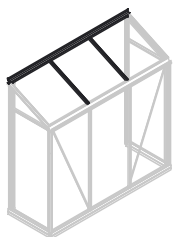

L=1504mm (2R) art 801530
L=2243mm (3R) art 801520
L=2981mm (4R) art 801521

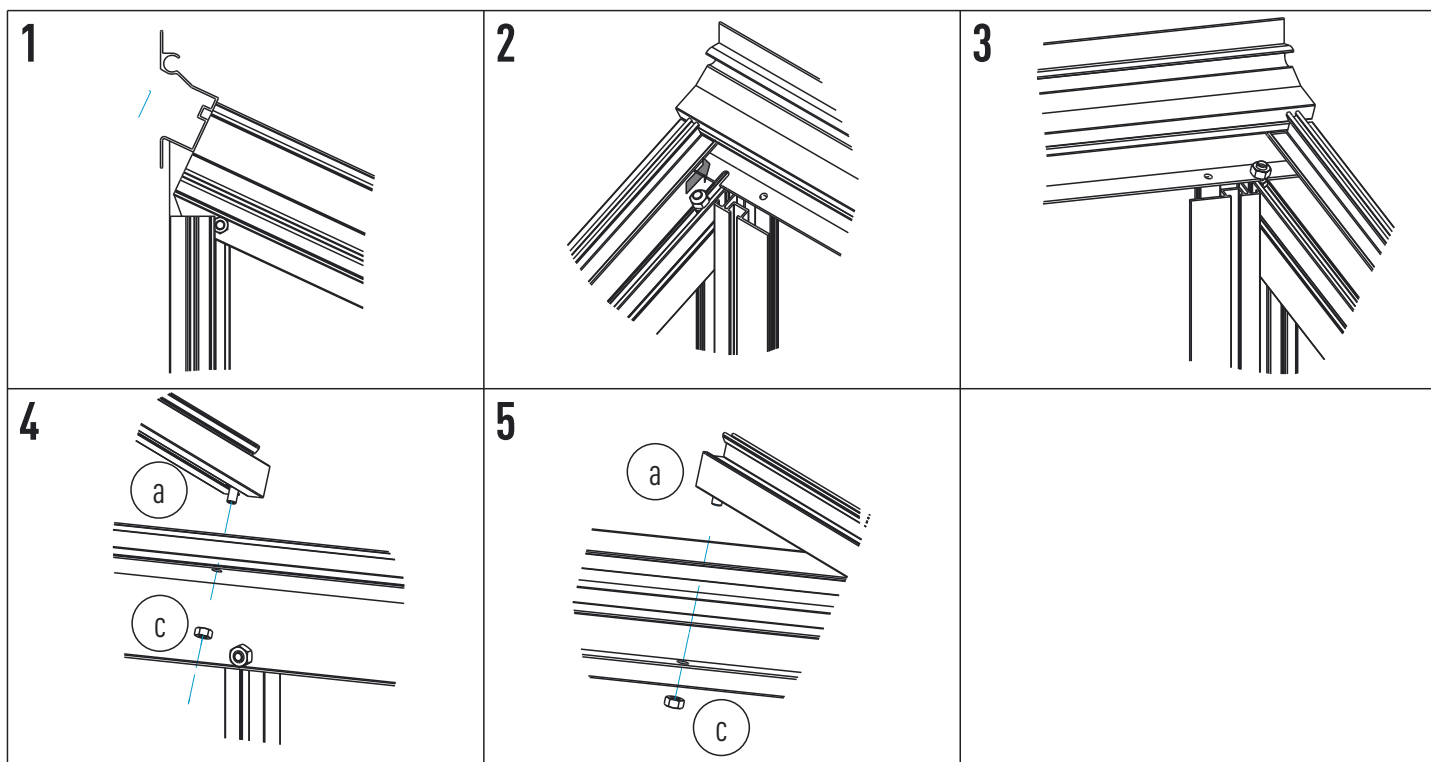
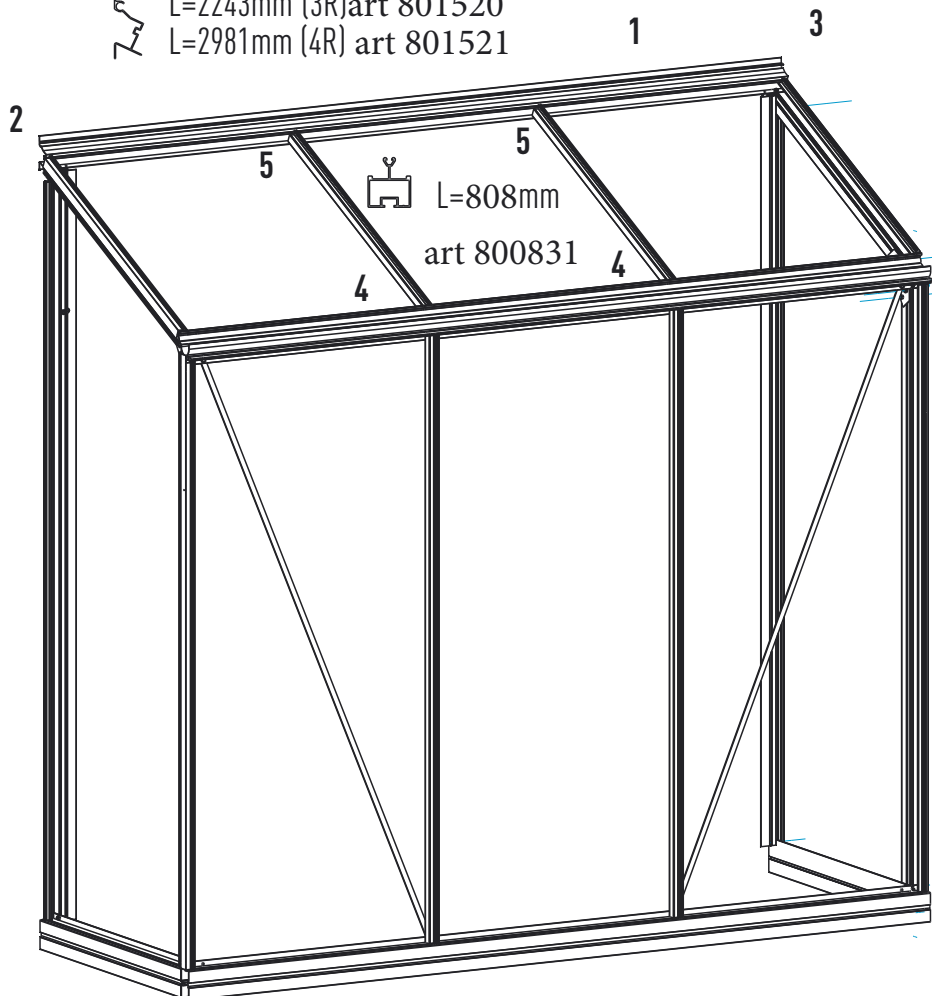

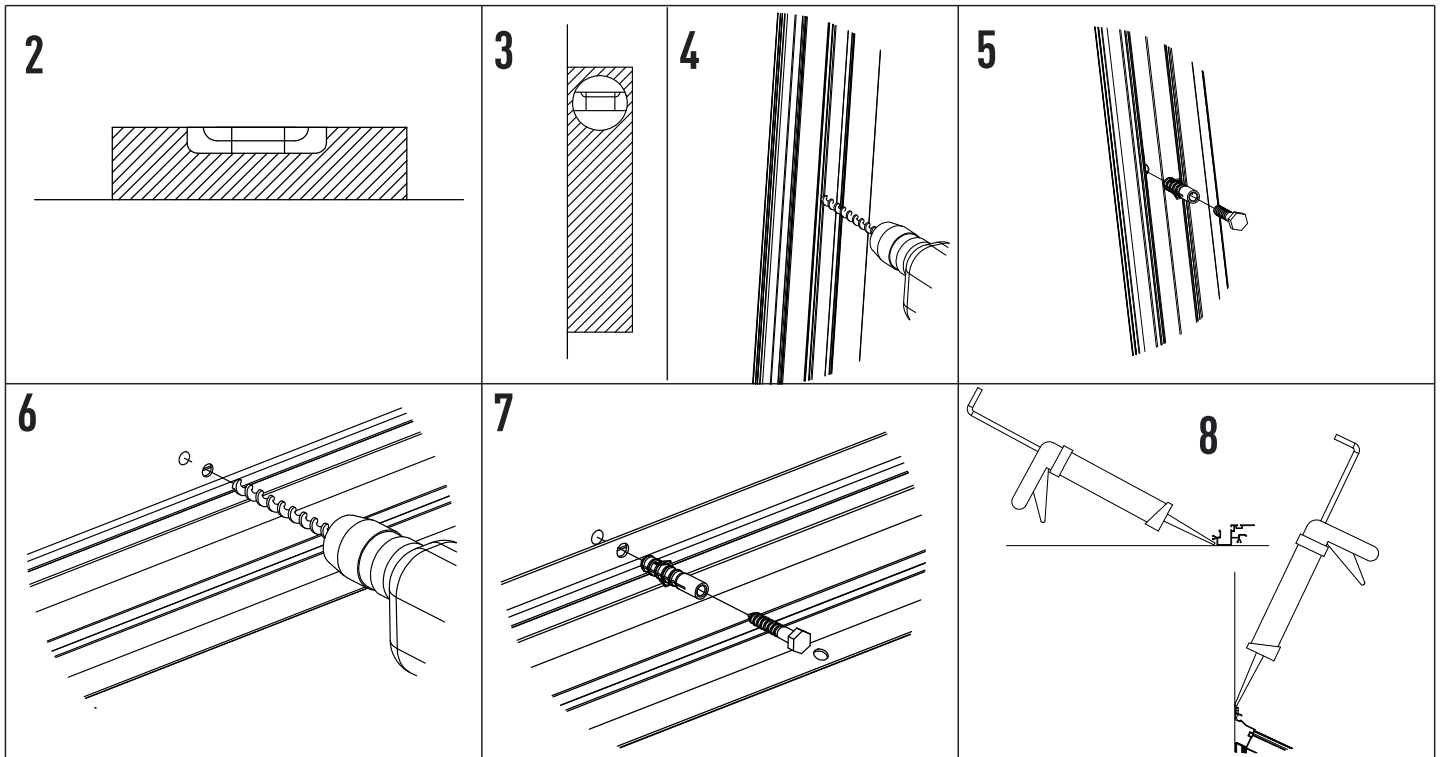
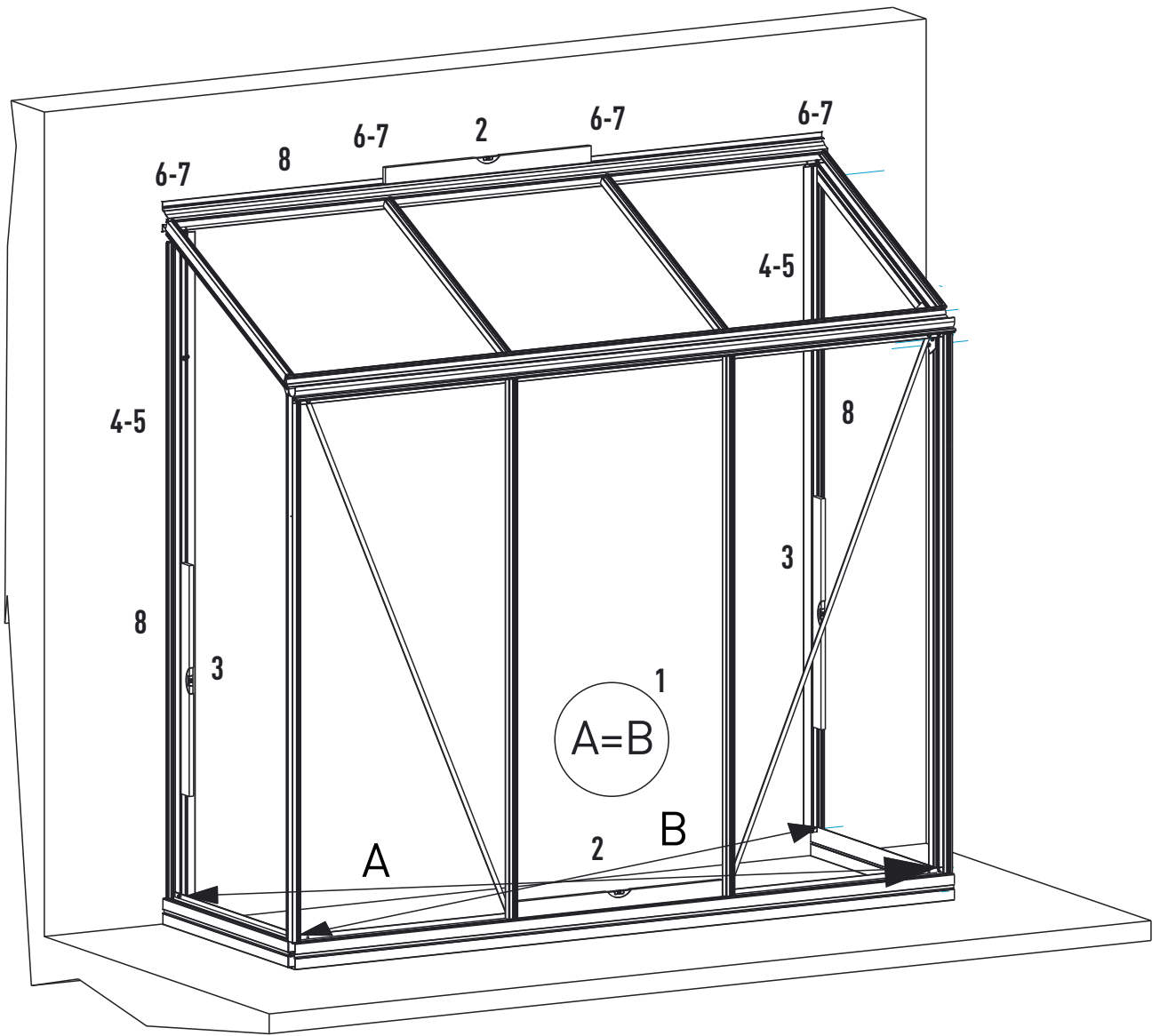

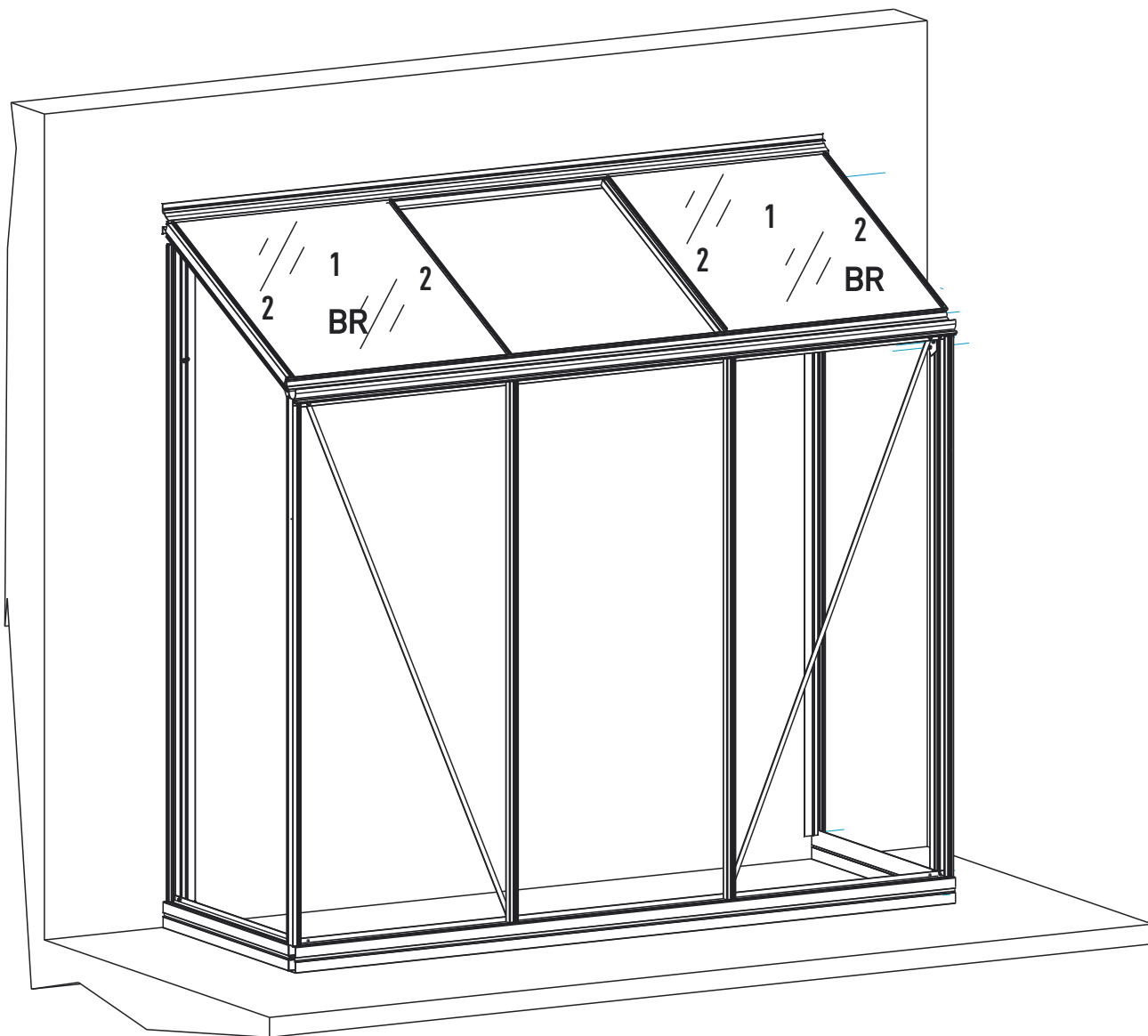

BR
817x730

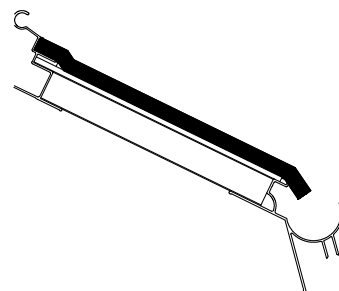
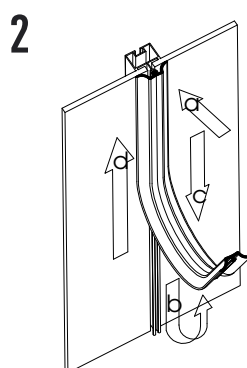
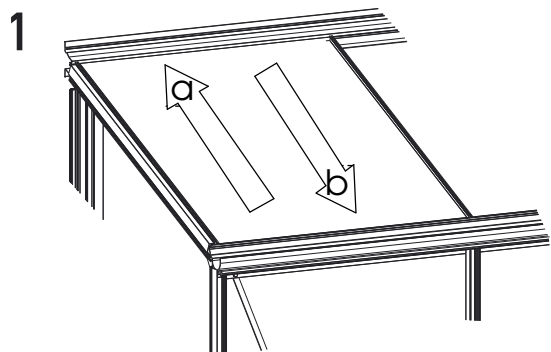

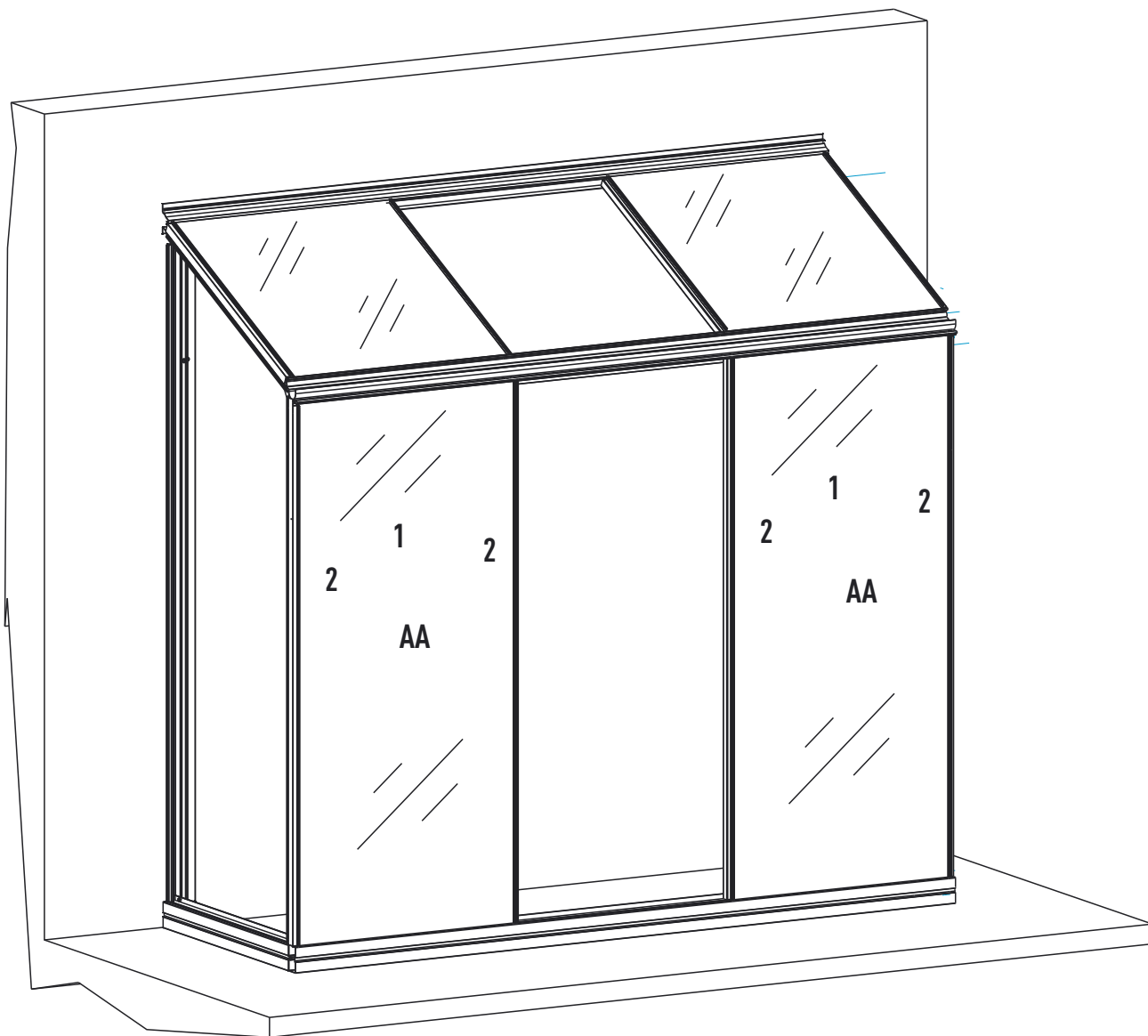

AA
1650x730

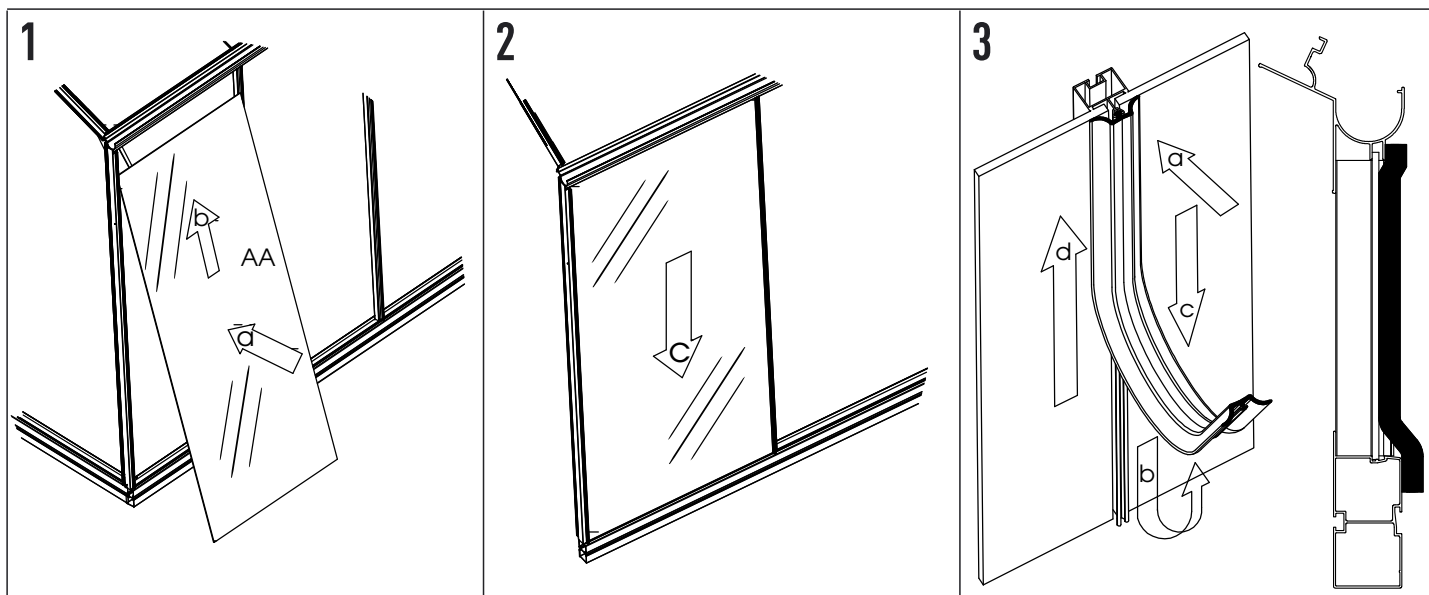

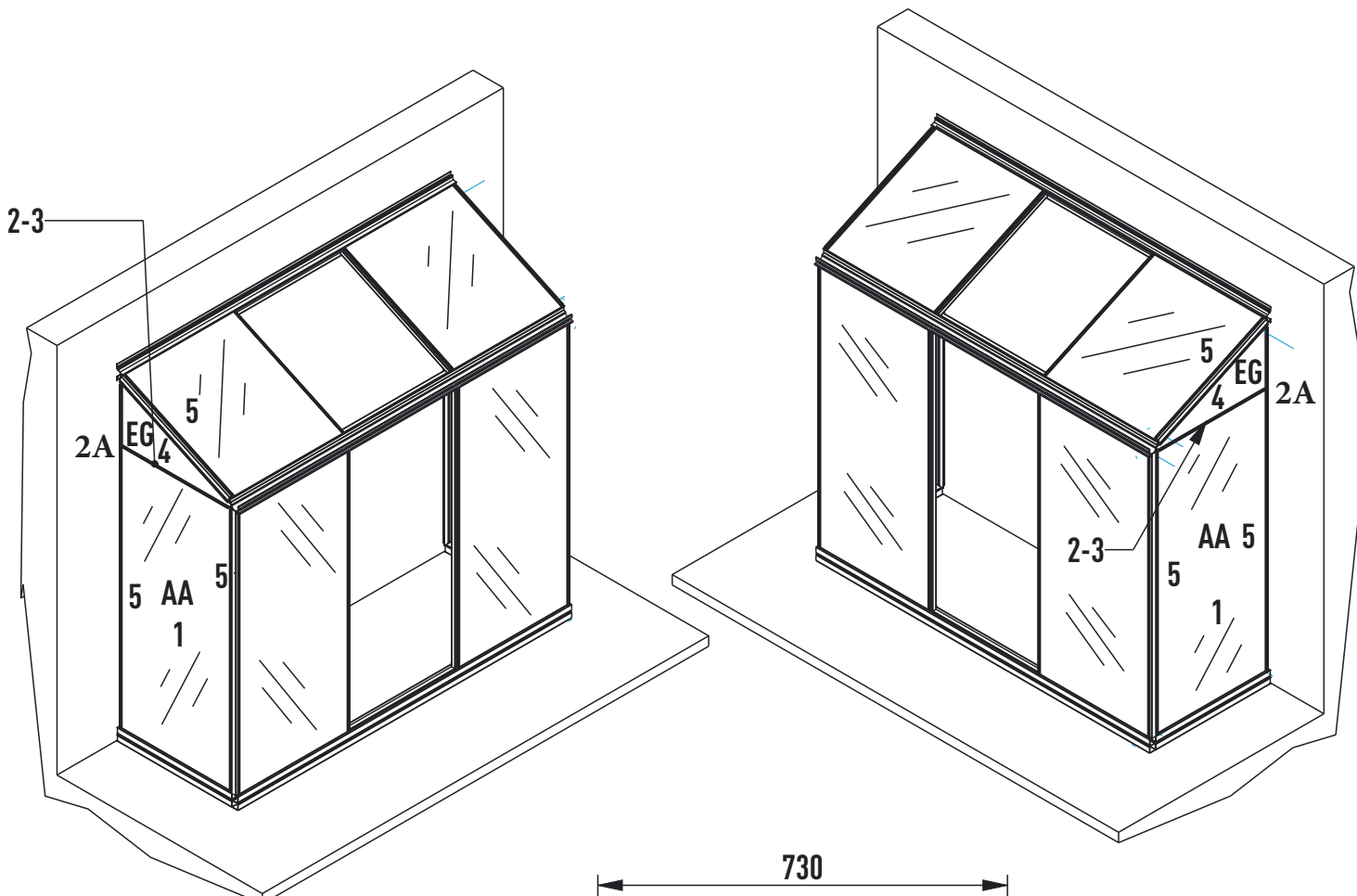

AA
1650x730 (2x)

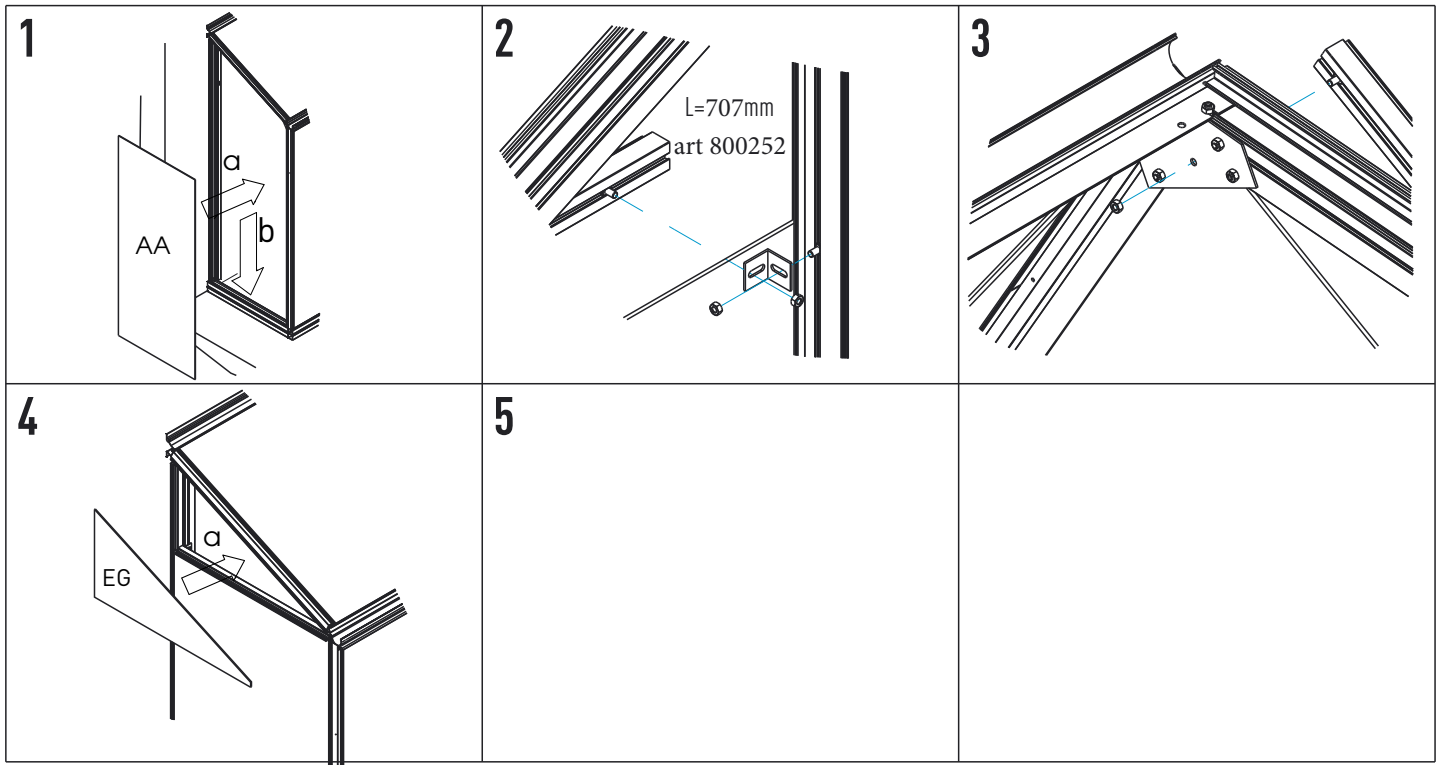
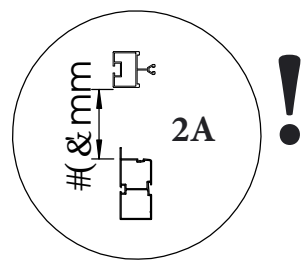
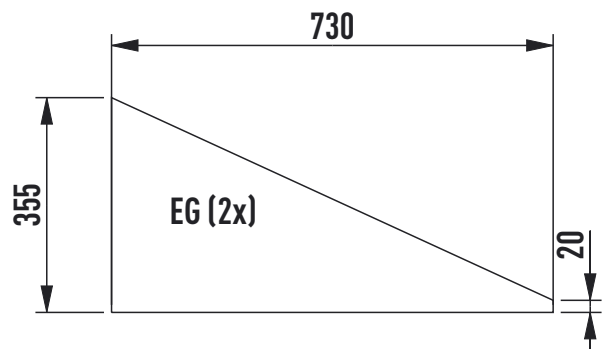

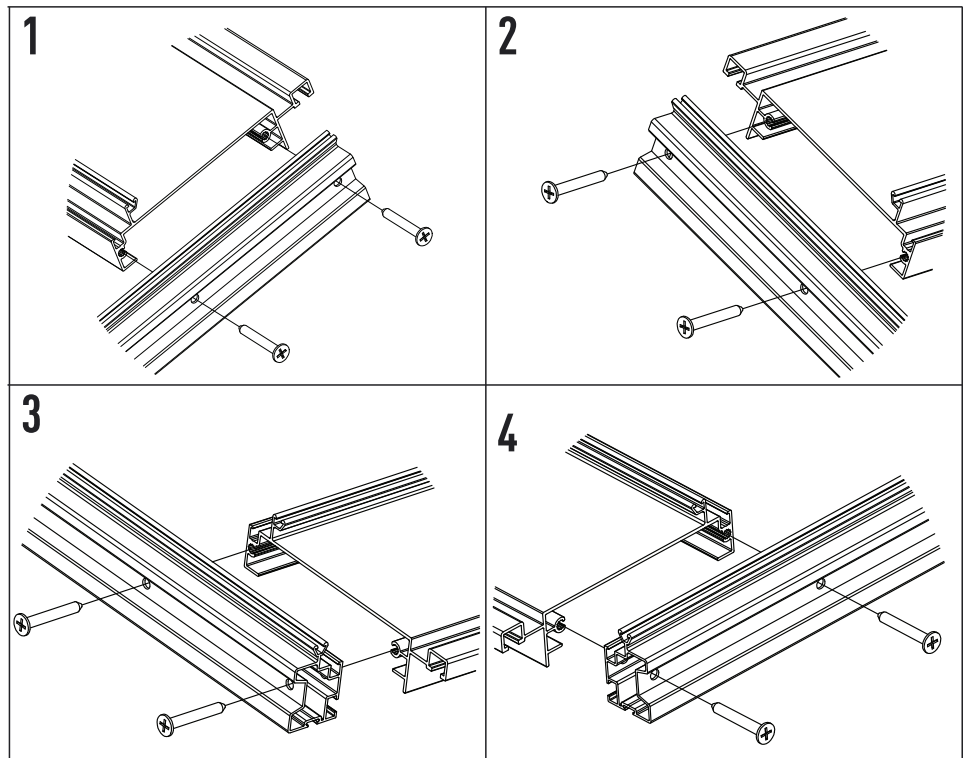
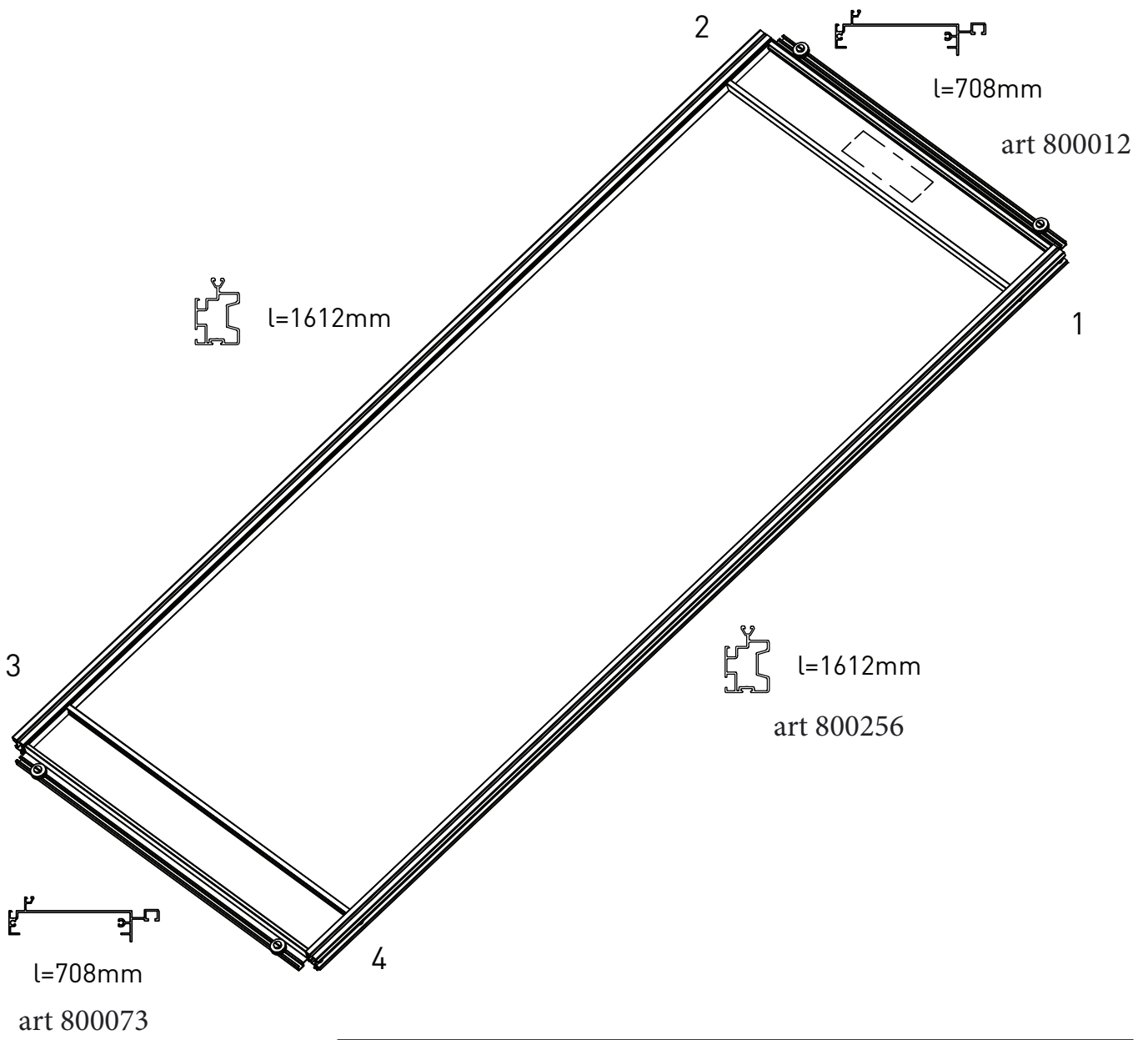

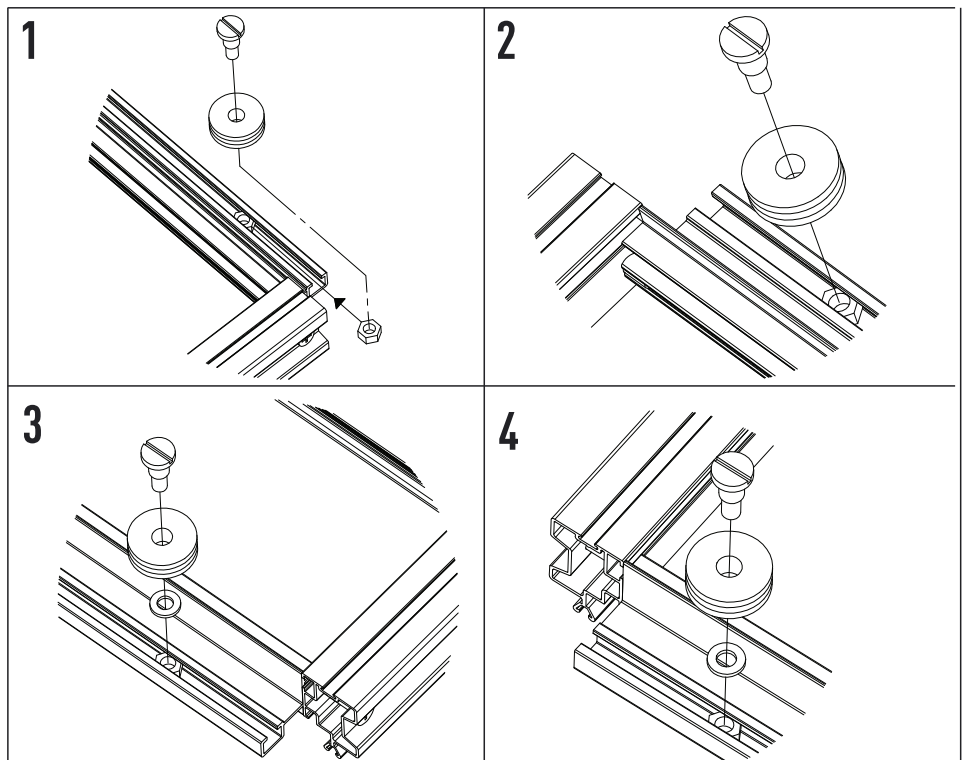
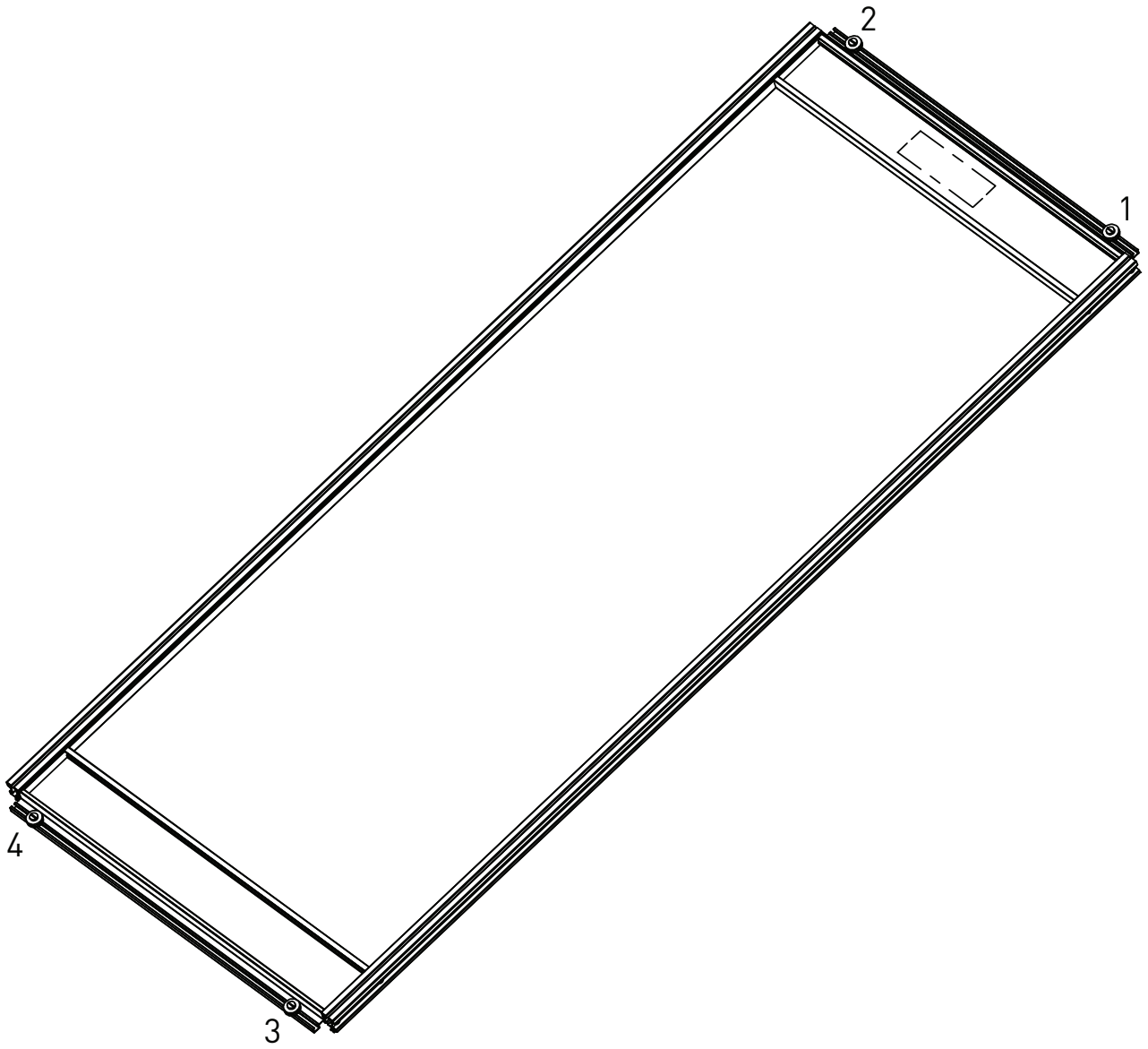

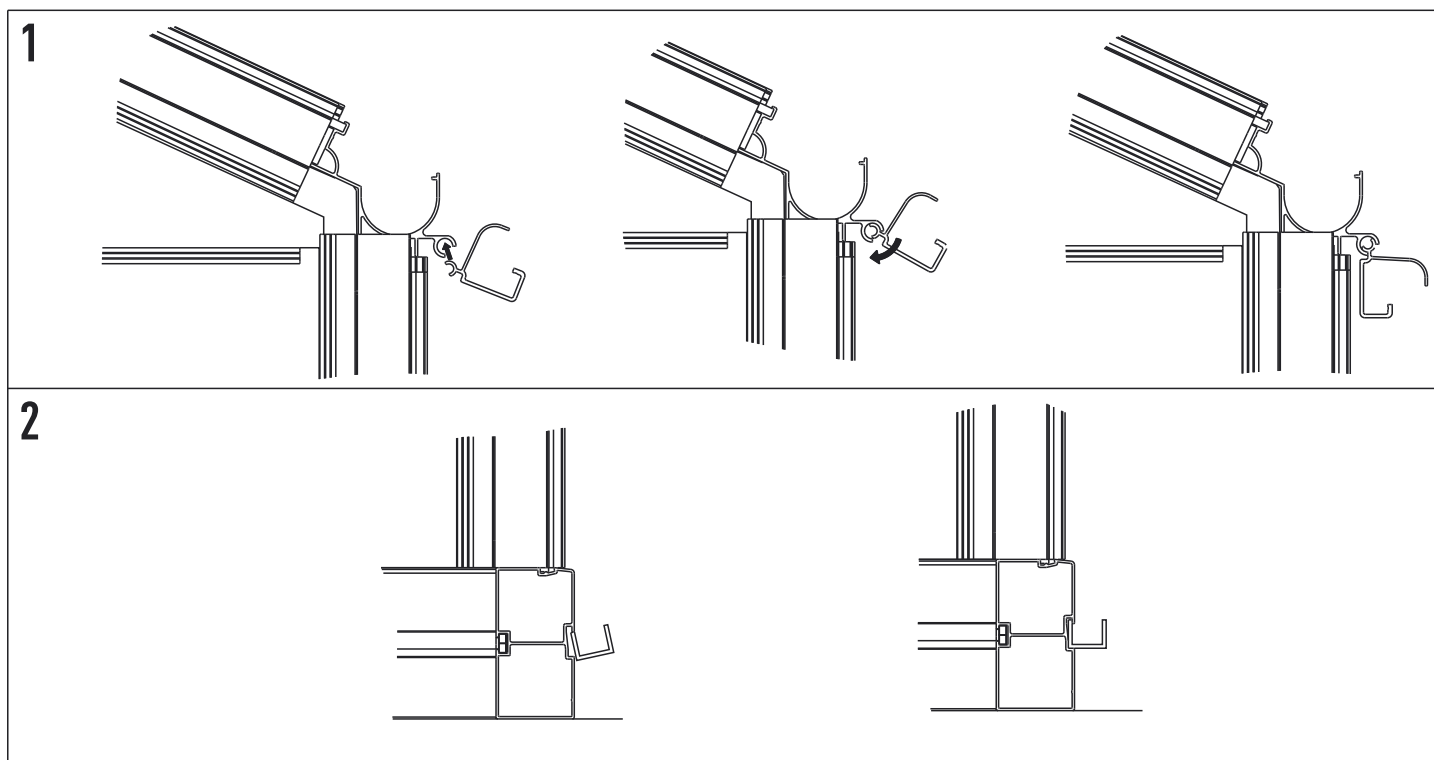
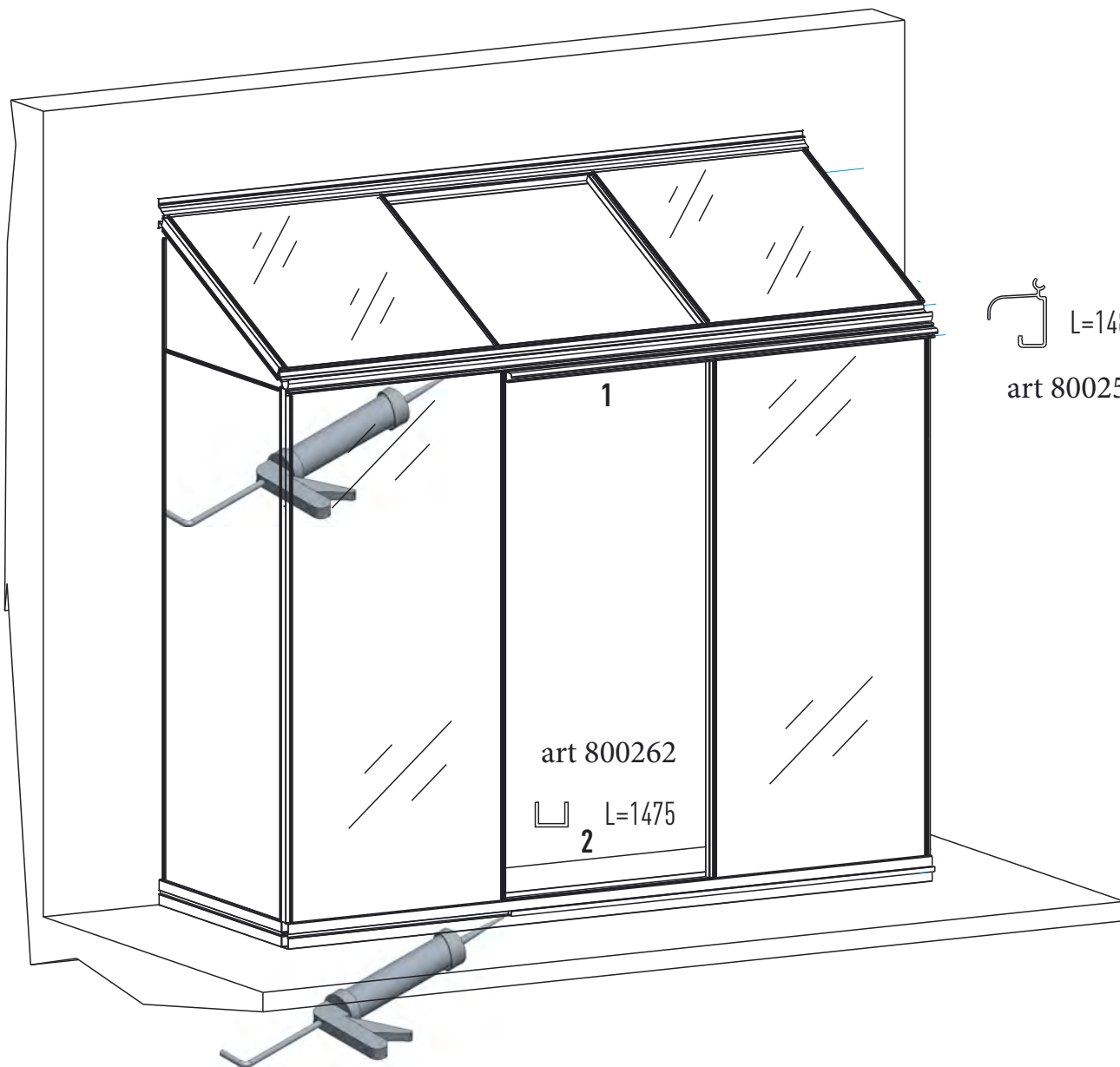

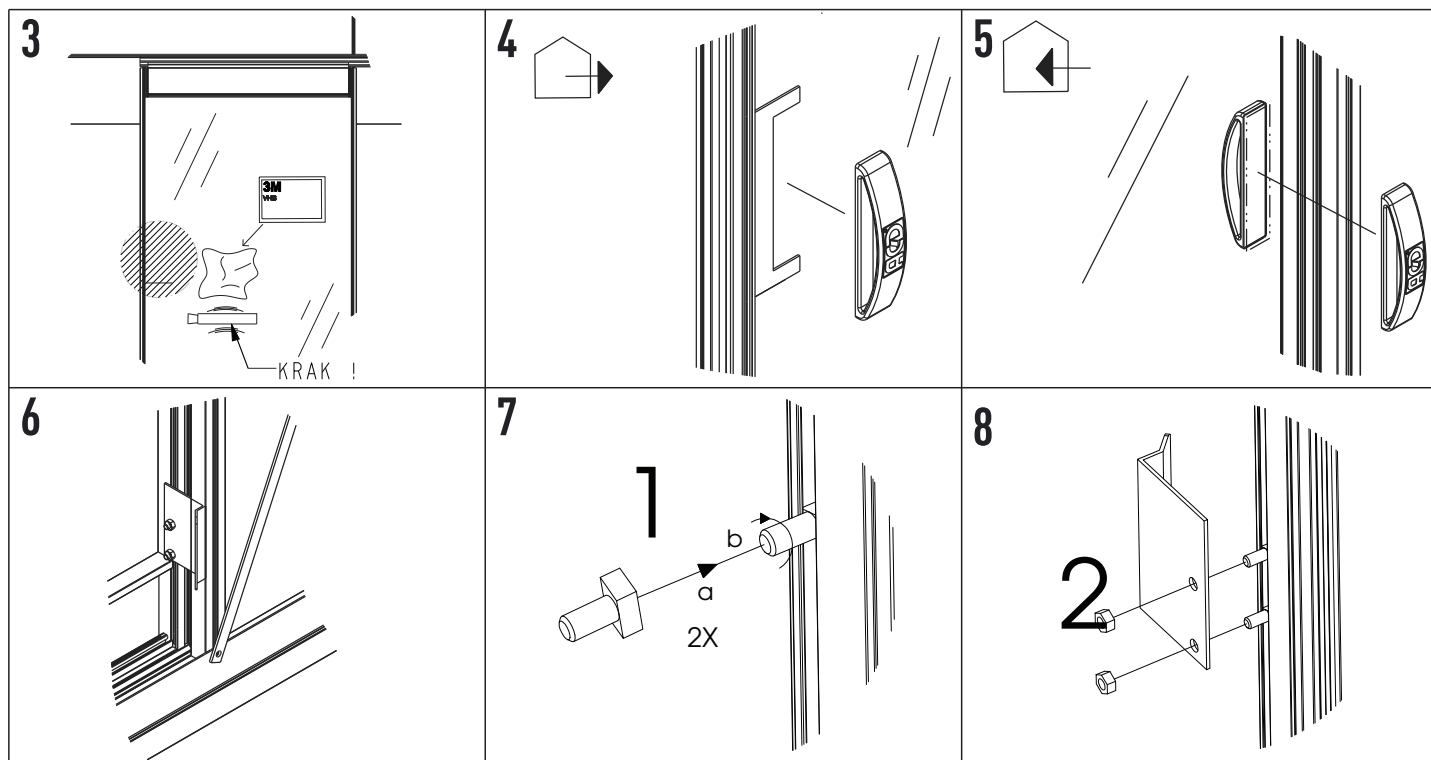
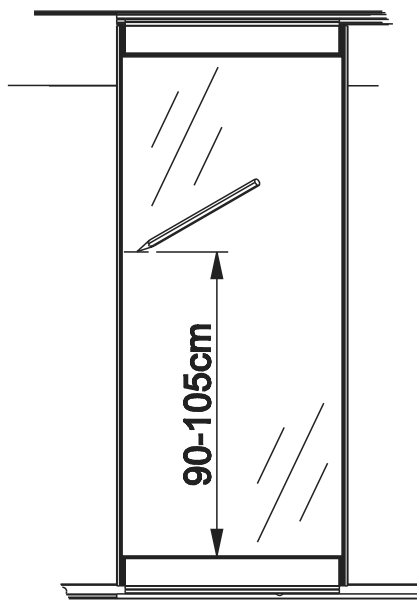
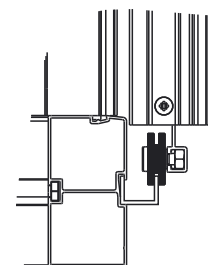
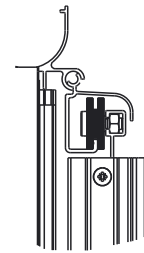
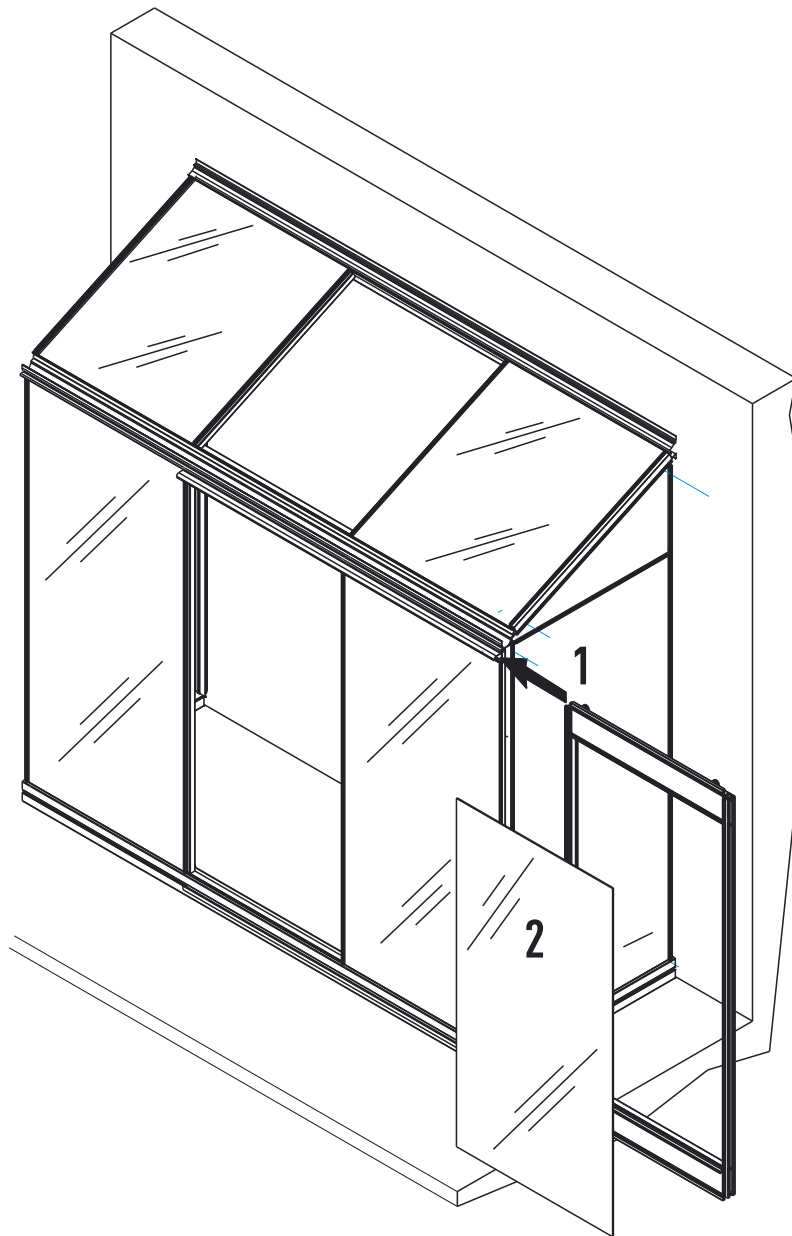

R3 - R4

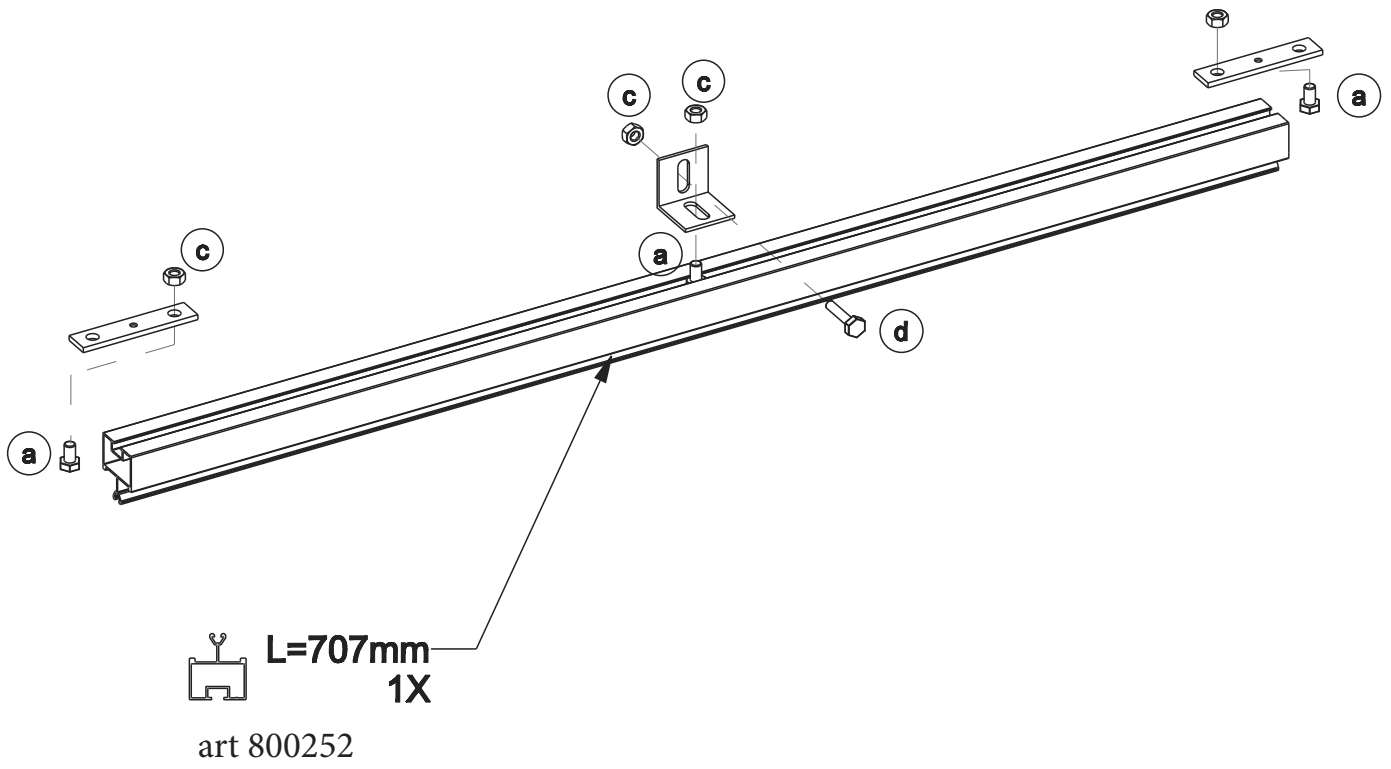

R2

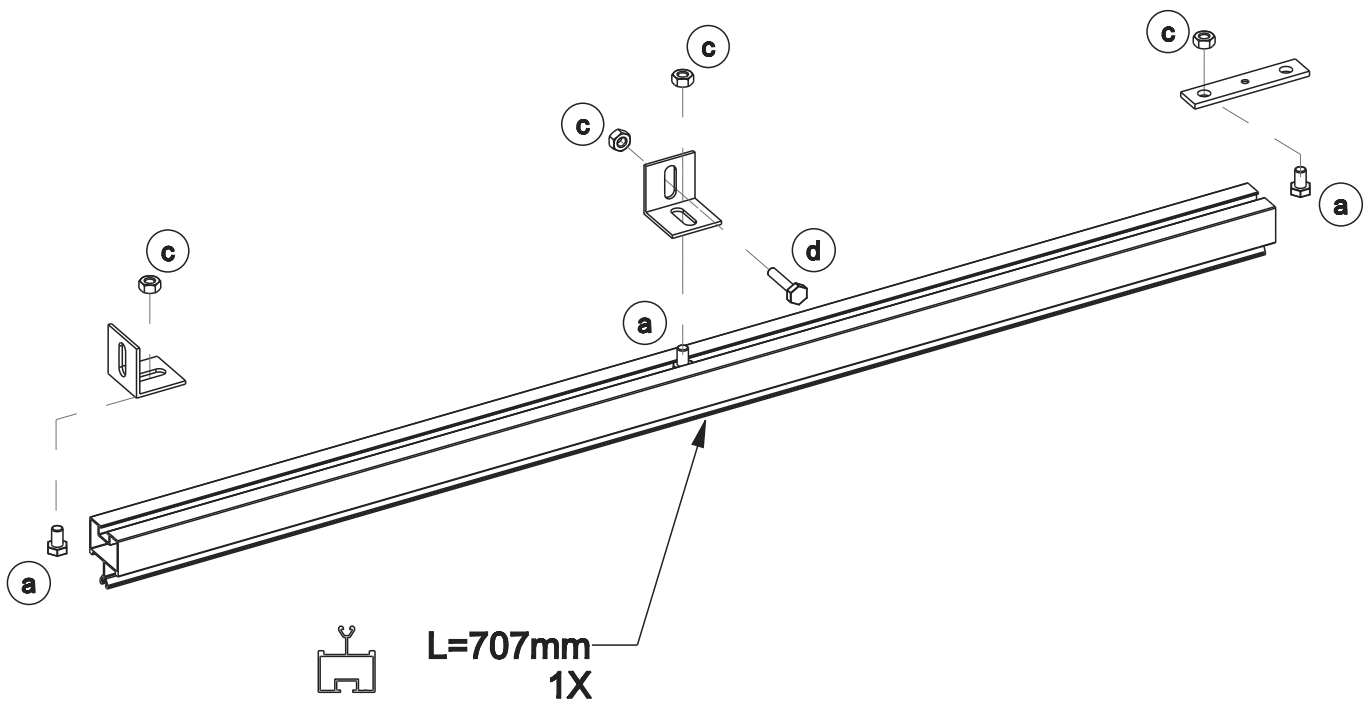

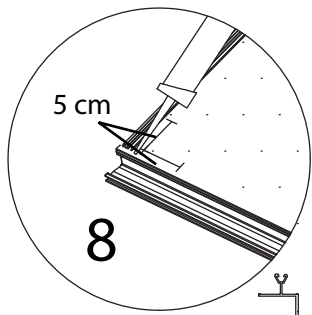

art 800038
l=770mm

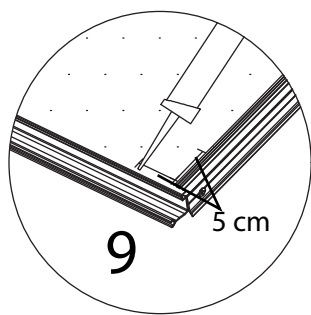
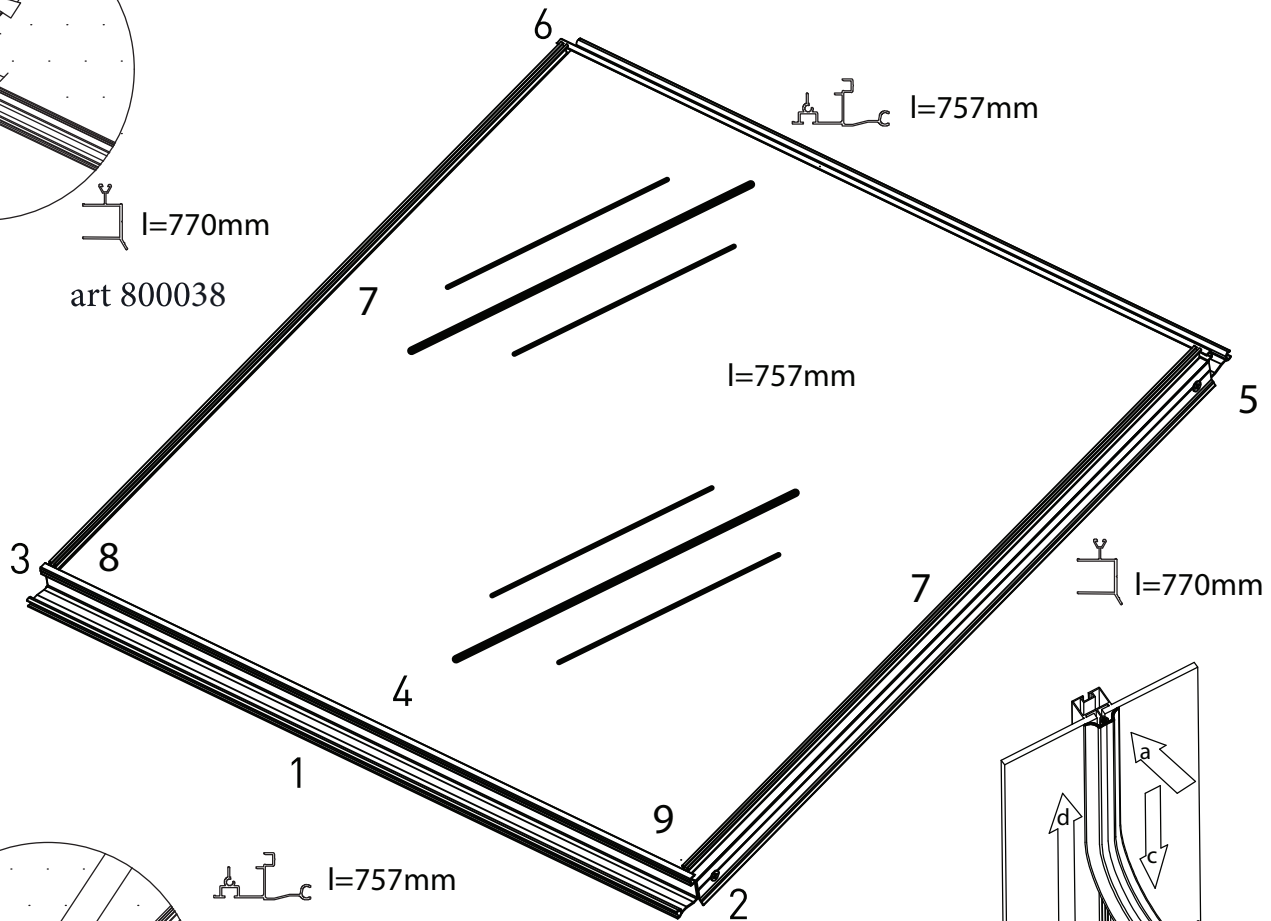

art 800089
l=757mm

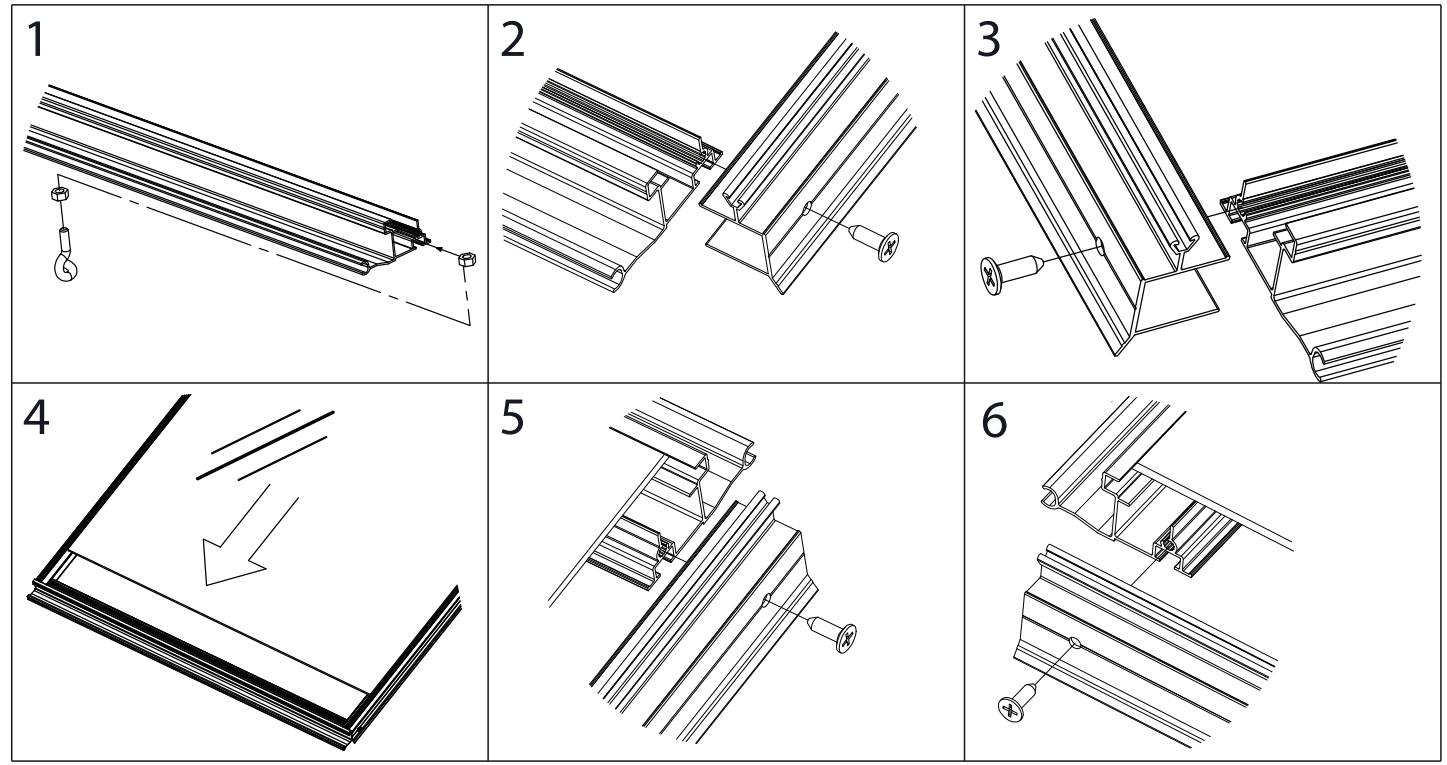
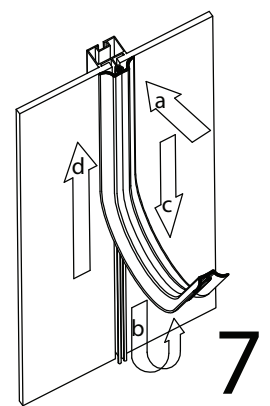

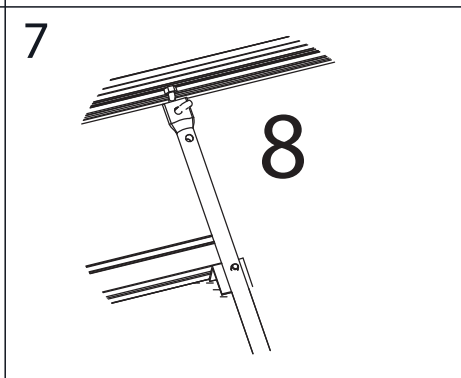
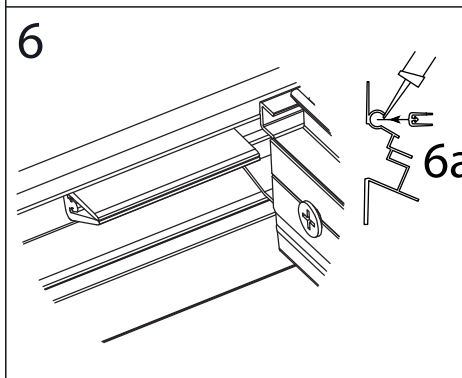
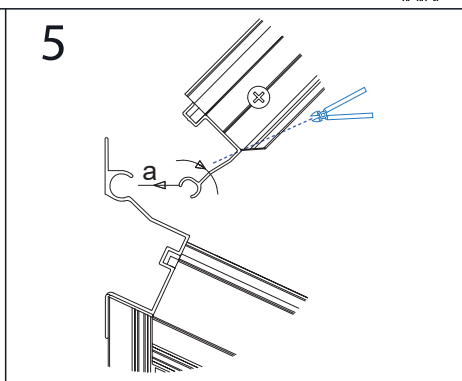
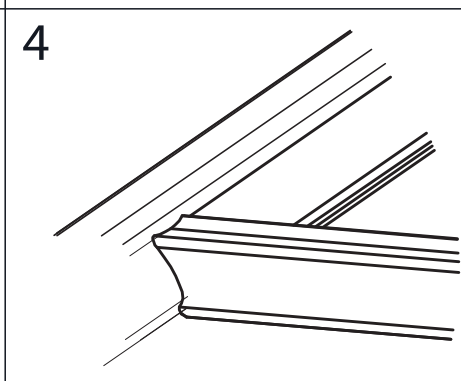
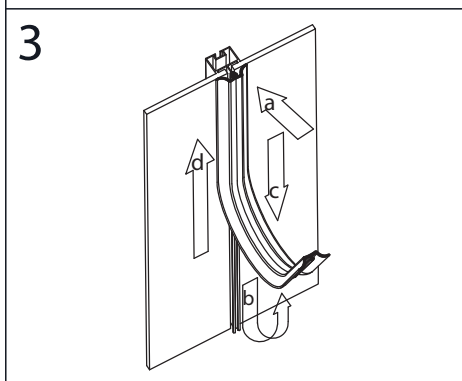
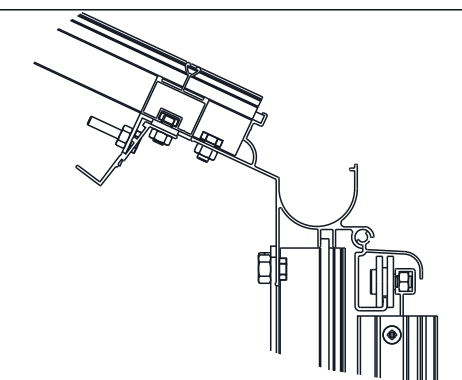
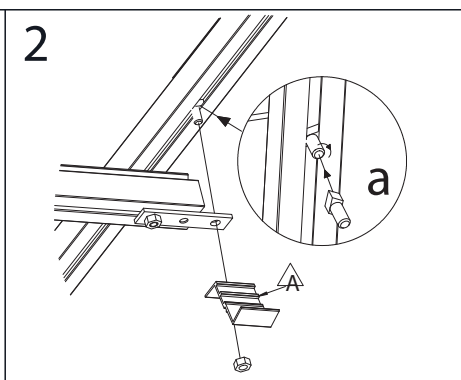
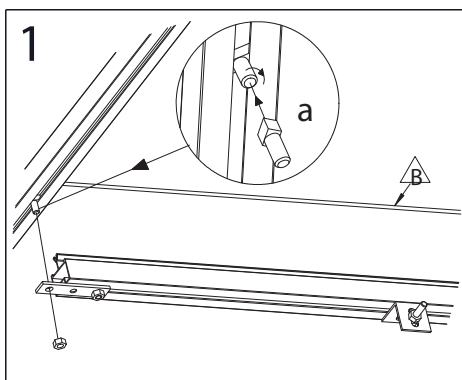
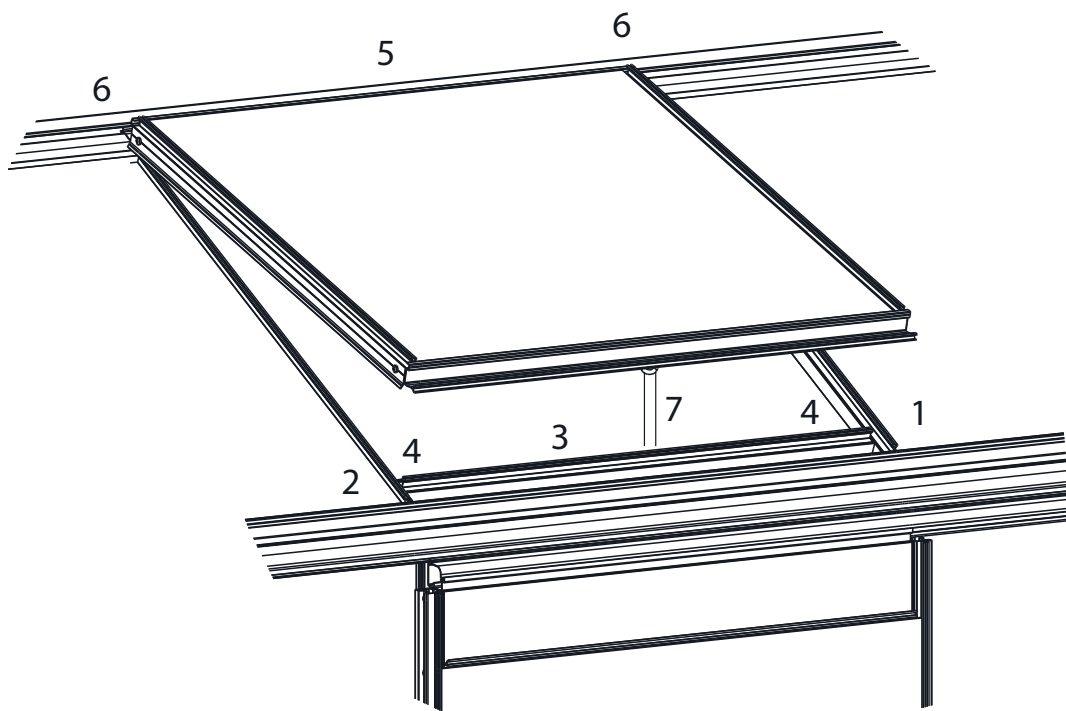

6 Knip stukjes van ± 5 cm van de meegeleverde rubber.
 Découpez morceaux de ± 5 cm du caoutchouc fourni.
 Cut pieces of ± 5 cm from the supplied rubber.
 Schneiden Sie aus dem mitgelieferten Gummi Stücke von ± 5 cm Länge aus.

